

AUTOMOTIVE INDUSTRY STANDARD

**Installation Requirements of
Lighting and Light-Signalling Devices
for Motor Vehicle having more than
Three Wheels, Trailer and Semi-Trailer
excluding Agricultural Tractor and
Special Purpose Vehicle**

PRINTED BY
THE AUTOMOTIVE RESEARCH ASSOCIATION OF INDIA
P.B. NO. 832, PUNE 411 004

ON BEHALF OF
AUTOMOTIVE INDUSTRY STANDARDS COMMITTEE

UNDER
CENTRAL MOTOR VEHICLE RULES – TECHNICAL STANDING COMMITTEE

SET-UP BY
MINISTRY OF ROAD TRANSPORT & HIGHWAYS
(DEPARTMENT OF ROAD TRANSPORT & HIGHWAYS)
GOVERNMENT OF INDIA

June 2010

Status chart of the standard to be used by the purchaser for updating the record

Sr. No.	Corrigenda.	Amendment	Revision	Date	Remark	Misc.
General remarks :						

INTRODUCTION

The Government of India felt the need for a permanent agency to expedite the publication of standards and development of test facilities in parallel when the work on the preparation of the standards is going on, as the development of improved safety critical parts can be undertaken only after the publication of the standard and commissioning of test facilities. To this end, the Ministry of Surface Transport (MOST) has constituted a permanent Automotive Industry Standard Committee (AISC) vide order No.RT-11028/11/97-MVL dated September 15, 1997. The standards prepared by AISC will be approved by the permanent CMVR Technical Standing Committee (CTSC). After approval, the Automotive Research Association of India, (ARAI), Pune, being the Secretariat of the AIS Committee, has published this standard. For better dissemination of this information ARAI may publish this document on their Web site.

Installation of lighting and light-signaling devices for motor vehicle having more than three wheels, trailer and semi-trailer is a safety requirement. This standard prescribes the requirements of such installation and is in force vide notification S.O. 1365(E) dated 13th December 2004.

With a continuous change in European Regulation to cater for new technologies, and enhanced safety requirements due to increased road speed, it was felt necessary to upgrade the standard to the level of European level up to October 2006.

While aligning the revision of this standard to ECE R 48 (Revision 4- Amendment 1- 03 series of amendments), upgradation in various requirements are incorporated. Summary of which is given below:

- definitions of different types of light sources such as replaceable, non-replaceable, light source module, filament light source, gas discharge light source.
- automatic leveling device and headlamp cleaning devices for the dipped-beam headlamps with a light source having an objective luminous flux which exceeds 2,000 lumens.
- maximum height of the installation of front fog lamp on M1 and N1 category vehicles is made stringent (not more than 800 mm above ground)
- mandatory installation of reversing lamps for trailers of category T2, T3 and T4.
- clarity on arrangements of installation of various categories of direction indicators and inclusion of category 6 of side-direction indicator.
- for M1 and N1 category vehicles, width requirement for installation of stop lamps (S1 or S2) from the extreme outer edge of the vehicle. Mandatory installation of S3 category stop lamp on N1 category vehicles.
- optional fitment of new types of lamps viz. Daytime Running Lamp used to make the vehicle more easily visible when driving during daytime.
- Cornering lamp used to provide enhanced illumination in bends which provides illumination of that part of the road which is located near the forward corner of the vehicle at the side towards which the vehicle is going to turn. Provision of these new types of lamps increases further safety to the user of both vehicle and Road.

Considerable assistance has been taken from the following ECE Regulations in preparing this standard:

ECE R 48 (Revision 4- Amendment 1- 03 series of amendments) : Uniform provisions concerning the approval of vehicles with regard to the installation of lighting and light-signaling devices.

The AISC panel and the Automotive Industry Standard Committee (AISC) responsible for preparation of this standard is given in Annex F and Annex G respectively.

**Installation Requirements of Lighting and Light - Signalling Devices for
Motor Vehicle having more than Three Wheels, Trailer and Semi-Trailer
excluding Agricultural Tractor and Special Purpose Vehicle**

Paragraph Nos.	Contents	Page No.
1.	Scope	1/66
2.	Definitions	1/66
3.	Reserved paragraph	9/66
4.	Reserved paragraph	9/66
5.	General Requirements	9/66
6.	Individual Specifications	15/66
7.	Technical Specifications to be Submitted	46/66
8.	Criteria for Extension of Approval	48/66
9.	Conformity of Production Requirements	49/66
10.	Transitional Provisions	49/66
ANNEXES		
Annex A	Indication of the Stated Initial Adjustment Referred to in paragraph 6.2.6.1.1 of this standard	53/66
Annex B	States of Loading to be taken into consideration in determining Variations in the Vertical Orientation of the Dipped-beam Headlamps	54/66
Annex C	Measurement of the variation of Dipped- beam inclination as a Function of Load (Ref. paragraph 6.2.6.3.2)	56/66
Annex D	The Controls for the Headlamp - Leveling Devices	61/66
Annex E	Examples of Light Source Options	63/66
Annex F	Composition of AISC panel on Lighting Installation for Four Wheelers	64/66
Annex G	Automotive Industry Standards Committee composition	66/66

Installation Requirements of Lighting and Light-Signalling Devices for Motor Vehicle having more than Three Wheels, Trailer and Semi -Trailer excluding Agricultural Tractor and Special Purpose Vehicle

1.0 SCOPE

This standard applies to the approval of power-driven vehicles intended for use on the road, with or without bodywork, with not less than four wheels and a maximum design speed exceeding 25 km/h, and of their trailers, with the exception of vehicles, which run on rails, agricultural or forestry tractors and machinery, and public works vehicles.

1.1 References

The following standards are necessary adjuncts to this standard:

- 1.1.1 IS: 9211-2003 "Terms and Definitions of Weights of Road Vehicles other than 2 and 3 wheelers".
- 1.1.2 AIS-053 "Automotive Vehicles - Types – Terminology".
- 1.1.3 AIS-012/2001 "Performance Requirements of Lighting and Light Signalling Devices for Motor Vehicle having more than Three Wheels, Trailer and Semi-Trailer
- 1.1.4 IS: 9435: 2004 "Terms and Definitions Relating to Dimensions of Road Vehicles".

2.0 DEFINITIONS

For the purpose of this standard the following definitions shall apply:

- 2.1. "**Approval of a vehicle**" means the approval of a vehicle type with regard to the number and mode of installation of the lighting and light-signalling devices;
- 2.2. "**Vehicle type**" with regard to the installation of lighting and light signalling devices means vehicles, which do not differ in the essential respects given below:
 - Dimensions and external shape of the vehicle,
 - Number and positioning of the devices,
 - Head lamp levelling system, if provided,
 - Suspension system.

The following shall likewise, not deemed to be vehicles of different type.

Vehicles which differ within the meaning of items mentioned above but not in such a way as to entail a change in the kind, number, positioning and geometric visibility of the lamp and inclination of the dipped-beam prescribed for the vehicle type in question. Vehicles on which optional lamps are fitted or absent.

- 2.3. **“Transverse plane”** means a vertical plane perpendicular to the median longitudinal plane of the vehicle.
- 2.4. **“Unladen vehicle”** means the vehicle in kerb weight condition as specified in IS: 9211-2003.
- 2.5. **“Laden vehicle”** means the vehicle loaded to its maximum permissible weight (GVW) as stated by the manufacturer who shall also specify the distribution of this weight between the axles.
- 2.6. **“Device”** means an element or an assembly of elements used to perform one or more functions.
- 2.7. **“Lamp”** means a device designed to illuminate the road or to emit a light signal to other road users. Rear registration plate lamps and retro reflectors are likewise to be regarded as lamps.
- 2.7.1. **Light source**^{1/}
 - 2.7.1.1 **“Light source”** means one or more elements for visible radiation, which may be assembled with one or more transparent envelopes and with a base for mechanical and electrical connection.

A light source may also be constituted by the extreme outlet of a light-guide, as part of a distributed lighting or light-signaling system not having a built-in outer lens;
 - 2.7.1.1.1 **“Replaceable light source”** means a light source which is designed to be inserted in and removed from the holder of its device without tool;
 - 2.7.1.1.2 **“Non-replaceable light source”** means a light source which can only be replaced by replacement of the device to which this light source is fixed; in case of a light source module: a light source which can only be replaced by replacement of the light source module to which this light source is fixed;
 - 2.7.1.1.3 **“Light source module”** means an optical part of a device which is specific to that device, is containing one or more non-replaceable light sources, and is only removable from its device with the use of tool(s). A light source module is so designed that regardless the use of tool(s), it is not mechanically interchangeable with any replaceable approved light source;
 - 2.7.1.1.4 **“Filament light source”** (filament lamp) means a light source where the element for visible radiation is one or more heated filaments producing thermal radiation;
 - 2.7.1.1.5 **“Gas-discharge light source”** means a light source where the element for visible radiation is a discharge arc producing electro-luminescence /fluorescence;

.....
1/ For clarification see Annex E.

- 2.7.1.1.6 **“Light-emitting diode (LED)”** means a light source where the element for visible radiation is one or more solid state junctions producing injection-luminescence/fluorescence;
- 2.7.1.2 **“Electronic light source control gear”** means one or more components between supply and light source to control voltage and/or electrical current of the light source;
- 2.7.1.2.1 **“Ballast”** means an electronic light source control gear between supply and light source to stabilize the electrical current of a gas-discharge light source;
- 2.7.1.2.2 **“Ignitor”** means an electronic light source control gear to start the arc of a gas-discharge light source.
- 2.7.2 **“Equivalent lamps”** means lamps having the same function. These may have different characteristics from those installed on the vehicle when it is approved on the condition that the lamps satisfy the requirements of this standard.
- 2.7.3 **“Independent lamp”** means a device having separate illuminating surface ^{1/} separate light source and separate lamp body.
- 2.7.4 **“Grouped lamp”** means a device having separate illuminating surface ^{1/} and separate light sources but a common lamp body.
- 2.7.5 **“Combined lamp”** means a device having separate illuminating surface ^{1/} but a common light source and a common lamp body.
- 2.7.6 **“Reciprocally incorporated lamp”** means a device having separate light sources or a single light source operating under different conditions (e.g. optical, mechanical, or electrical differences), totally or partially common illuminating surfaces ^{1/} and a common lamp body.
- 2.7.7 **“Single function lamp”** means a device or a part of a device which performs a single lighting or light signalling function.
- 2.7.8 **“Concealable lamp”** means a lamp capable of being partly or completely hidden when not in use. This result may be achieved by means of a movable cover by displacement of the lamp or by any other suitable means. The term “retractable” is used more particularly to describe a concealable lamp the displacement of which enables it to be inserted within the body work.
- 2.7.9 **“Main-beam headlamp”** means the lamp used to illuminate the road over a long distance ahead of the vehicle.

^{1/} In the case of lighting devices for the rear registration plate (mark) and the direction indicators (category 5 and 6), light emitting surface can replace an illuminating surface.

- 2.7.10 **“Dipped-beam headlamp”** means the lamp used to illuminate the road ahead of the vehicle without causing undue dazzle or discomfort to oncoming drivers and other road users.
- 2.7.11 **“Direction-indicator lamp”** means the lamp used to indicate to other road users that the driver intends to change direction to the right or to the left. A direction-indicator lamp or lamps may also be used according to the provisions of AIS-076;
- 2.7.12 **“Stop lamp”** means the lamp used to indicate to other road users to the rear of the vehicle that the longitudinal movement of the vehicle is intentionally retarded.
- 2.7.13 **“Rear registration plate (mark) illuminating lamp”** means the device used to illuminate the space intended to accommodate the rear registration plate. This may consist of different optical components.
- 2.7.14 **“Front position lamp”** means the lamp used to indicate the presence and the width of the vehicle when viewed from the front.
- 2.7.15 **“Rear position lamp”** means the lamp used to indicate the presence and the width of the vehicle when viewed from the rear.
- 2.7.16 **“Retro-reflector”** means a device used to indicate the presence of a vehicle by the reflection of light emanating from a light source not connected to the vehicle, the observer being situated near the source.
- 2.7.16.1. retro-reflecting number plates;
- 2.7.16.2. the retro-reflecting signals mentioned in the ADR (European Agreement concerning the international carriage of dangerous goods by road);
- 2.7.16.3. other retro-reflective markings plates and signals which shall be used to comply with national requirements for use as regards certain categories of vehicles or certain methods of operation;
- 2.7.16.4 retro-reflecting materials approved as Class D or E according to Regulation No. 104 and used for other purposes in compliance with national requirements, e.g. advertising.
- 2.7.17. Reserved
- 2.7.18 **“Hazard warning signal”** means the simultaneous operation of all the direction indicator lamps of a vehicle to draw attention to the fact that the vehicle temporarily constitutes a special danger to other road users.
- 2.7.19 **“Front fog lamp”** means the lamp used in case of fog, snowfall, rainstorms or dust clouds to improve the illumination of the road.
- 2.7.20 **“Rear fog lamp”** means the lamp used to make the vehicle more easily visible from the rear in dense fog, snowfall, rainstorms or dust clouds.

- 2.7.21 **“Reversing lamp”** means the lamp used to illuminate the road to the rear of the vehicle and to warn other road users that the vehicle is reversing or about to reverse.
- 2.7.22 **“Parking lamp”** means the lamp used to draw attention to the presence of a stationary vehicle in a built up area. In such circumstances it replaces the front and rear position lamps.
- 2.7.23 **“End outline marker lamp”** means the lamp fixed to the extreme outer edge as close as possible to the top of the vehicle and intended to indicate clearly the overall width of the vehicle. This lamp is intended for certain vehicles and trailers to complement the front and rear position lamps of the vehicle by drawing particular attention to its bulk.
- 2.7.24 **“Side-marker lamp”** means a lamp used to indicate the presence of the vehicle when viewed from the side.
- 2.7.25 **“Day time running lamp”** means a lamp facing in a forward direction used to make the vehicle more easily visible when driving during daytime.
- 2.7.26. **“Cornering lamp”** means a lamp used to provide supplementary illumination of that part of the road which is located near the forward corner of the vehicle at the side towards which the vehicle is going to turn;
- 2.7.27. **“Objective luminous flux”** means a design value of the luminous flux of a replaceable light source. It shall be achieved, within the specified tolerances, when the replaceable light source is energized by the power supply at the specified test voltage, as indicated in the data sheet of the light source;
- 2.8 **“Light emitting surface of a "Lighting Device", "Light-Signalling Device" or a "Retro-Reflector" means all or part of the exterior surface of the transparent material as specified by the device manufacturer on the drawing of device. (Ref.Fig.1 and Fig.2)**
- 2.9 **Illuminating Surface (Ref. Fig. 1 and Fig. 2).**
- 2.9.1 **“Illuminating surface of a lighting device”** (paragraphs 2.7.9, 2.7.10, 2.7.19, 2.7.21, and 2.7.26) means the orthogonal projection of the full aperture of the reflector, or in the case of head lamps with an ellipsoidal reflector of the “projection lens”, on a transverse plane. If the lighting device has no reflector, the definition of paragraph 2.9.2 shall be applied. If the light emitting surface of the lamp extends over a part only of the full aperture of the reflector, then the projection of that part only is taken into account. In the case of a dipped-beam headlamp, the illuminating surface is limited by the apparent trace of the cut-off on the lens. If the reflector and lens are adjustable relative to one another, the mean adjustment should be used.

2.9.2 **“Illuminating surface of a light-signalling device other than a retro reflector”** (paragraphs 2.7.11, to 2.7.15, 2.7.18, 2.7.20 and 2.7.22. to 2.7.25) means the orthogonal projection of the lamp in a plane perpendicular to its axis of reference and in contact with the exterior light emitting surface of the lamp, this projection being bounded by the edges of the screens situated in this plane, each allowing only 98 % of the total luminous intensity of the light to persist in the direction of the axis of reference.

To determine the lower, upper and lateral limits of the illuminating surface only screens with horizontal or vertical edges shall be used to verify the distance to the extreme edges of the vehicle and the height above the ground.

For other applications of the illuminating surface, e.g. distance between two lamps or functions, the shape of the periphery of this illuminating surface shall be used. The screens shall remain parallel, but other orientations are allowed to be used.

In the case of a light-signalling device whose illuminating surface encloses either totally or partially the illuminating surface of another function or encloses a non-lighted surface, the illuminating surface may be considered to be the light emitting surface itself.

2.9.3 **“Illuminating surface of a retro-reflector”** (paragraph 2.7.16.) means, as declared by the applicant during the component approval procedure for the retro-reflectors, the orthogonal projection of a retro-reflector in a plane perpendicular to its axis of reference and delimited by planes contiguous to the declared outermost parts of the retro-reflectors' optical system and parallel to that axis. For the purposes of determining the lower, upper and lateral edges of the device, only horizontal and vertical planes shall be considered.

2.10 **“Apparent surface”** means the apparent surface for a defined direction of observation means, at the request of the manufacturer, the orthogonal projection of:

Either the boundary of the illuminating surface projected on the exterior surface of the lens (a – b), or the light-emitting surface (c–d), in a plane perpendicular to the direction of observation and tangential to the most exterior point of the lens (Ref. Fig.1 and Fig. 2).

2.11 **“Axis of reference / reference axis”** means the characteristic axis of the lamp determined by the lamp manufacturer for use as the direction of reference ($H=0^\circ$, $V=0^\circ$) for angles of field for photometric measurements and for installing the lamp on the vehicle.

2.12 **“Centre of reference / reference Centre”** means the intersection of the axis of reference with the exterior light-emitting surface. This centre of reference is to be specified by the manufacturer of the lamp.

- 2.13 **“Angles of geometric visibility”** means the angles which determine the field of the minimum solid angle in which the apparent surface of the lamp shall be visible. That field on the solid angles is determined by the segments of the sphere of which the centre coincides with the centre of reference of the lamp and the equator is parallel with the ground. These segments are determined in relation to the axis of reference. The horizontal angles β correspond to the longitude and the vertical angles α to the latitude. There shall be no obstacle on the inside of the angles of geometric visibility to the propagation of light from any part of the apparent surface of the lamp observed from infinity.

If measurements are taken closer to the lamp, there shall be a parallel shift in the direction of observation to achieve the same accuracy. No account shall be taken of obstacles on the inside of the angles of geometric visibility, if they were already present when the lamp was type approved.

If, when the lamp is installed, any part of the apparent surface of the lamp is hidden by any further parts of the vehicle, proof shall be furnished that the part of the lamp not hidden by obstacles still conforms to the photometric values prescribed for the approval of the device as an optical unit (See Fig.1). Nevertheless, when the vertical angle of geometric visibility below the horizontal may be reduced to 5° (lamp at less than 750 mm above the ground level) the photometric field of measurements of the installed optical unit may be reduced to 5° below the horizontal.

- 2.14 **“Extreme outer edge on either side of the vehicle”** means the plane parallel to the median longitudinal plane of the vehicle and touching its lateral outer edge, disregarding the projection :
- 2.14.1. of tyres near their point of contact with the ground and connections for tyre - pressure gauges.
 - 2.14.2 of anti-skid devices which may be mounted on the wheels.
 - 2.14.3 of rear view mirrors.
 - 2.14.4 of side-direction-indicator lamps, end-outline marker lamps, front and rear position lamps, parking lamps, retro-reflectors and side-marker lamps.
 - 2.14.5 of seals affixed to the vehicle and of devices for securing and protecting such seals.
- 2.15 **“Overall width”** means the distance between the two vertical planes of the extreme outer edges defined in paragraph 2.14.

- 2.16 **Single and multiple lamps**
- 2.16.1. A **'Single lamp'** means
- a) a device or part of a device, having one lighting or light – Signalling function, one or more light source and one apparent surface in the direction of reference axis, which may be a continuous surface or composed of two or more distinct parts or,
 - b) any assembly of two independent lamps, whether identical or not, having the same function, both approved as type "D" lamp and installed so that the projections of their apparent surfaces in the direction of the reference axis occupies not less than 60% of the smallest quadrilateral circumscribing the projections of the said apparent surfaces in the direction of the reference axis.
- 2.16.2. **"Two lamps or an even number of lamps"** means a single light emitting surface in the shape of a band or strip is placed symmetrically in the relation to the median longitudinal plane of the vehicle and extending on both sides to within not less than 400 mm of the extreme outer edge of the vehicle and being not less than 800 mm long. The illumination of such a surface shall be provided by not less than two light sources placed as close as possible to its ends. The light emitting surface may be constituted by a number of juxtaposed elements on condition that the projections of the several individual light emitting surfaces on the same transverse plane occupy not less than 60% of the area of the smallest rectangle circumscribing the projections of those individual light emitting surfaces.
- 2.17 **"Distance between two lamps facing the same direction"** means the shortest distance between the two apparent surfaces in the direction of the reference axis. Where the distance between the lamps clearly meets the requirements of the standard, the exact edges of the apparent surfaces need not be determined.
- 2.18 **"Operating tell-tale"** means a visual or auditory signal (or any equivalent signal) indicating that a device has been switched on and is operating correctly or not.
- 2.19 **"Circuit closed tell-tale"** means a visual (or any equivalent signal) indicating that a device has been switched on, but not indicating whether it is operating correctly or not.
- 2.20 **"Optional lamp"** means a lamp the presence of which is left to the discretion of the vehicle manufacturer.
- 2.21 **"Ground"** means the surface on which the vehicle stands, which should be substantially horizontal.
- 2.22 **"Movable components of the vehicle"** means those body panels or other vehicle parts the position of which can be changed by tilting rotating or sliding without the use of tools. They do not include tiltable driver cabs of trucks.
- 2.23. **"Normal position of use of a movable component"** means the position(s) of a movable component specified by a vehicle manufacturer for the normal condition of use and the park condition of the vehicle.

- 2.24. **“Normal condition of use of vehicle”** means:
- 2.24.1 for a motor vehicle when the vehicle is ready to move with its propulsion engine running and its movable components in the normal position(s) as defined in 2.23
- 2.24.2 and for a trailer when the trailer is connected to drawing vehicle in the condition described in 2.24.1 and its movable components are in the normal position(s) as defined in 2.23
- 2.25 **“Park-condition of a vehicle”** means
- 2.25.1 for a motor vehicle is at a standstill and the propulsion engine is not running and its movable components are in its normal position(s) as defined in the 2.23.
- 2.25.2 and for a trailer when the trailer is connected to a drawing vehicle in the condition as described in 2.25.1 and its movable components are in the normal position(s) as defined in 2.23.
- 2.26 **"Bend lighting"** means a lighting function to provide enhanced illumination in bends.
- 3.0** Reserved paragraph
- 4.0** Reserved paragraph
- 5.0 GENERAL REQUIREMENTS**
- 5.1 Only those lighting and light signalling devices referred to in 6.0 of this standard shall be permitted to be installed on motor vehicles.
- The lighting and light signalling devices shall be so fitted that under normal conditions of use as defined in 2.24 and notwithstanding any vibration to which they may be subjected to, they retain the characteristics laid down in this standard and enable the vehicle to comply with the requirements of this standard. In particular, it shall not be possible for the adjustment of the lamps to be inadvertently disturbed.
- 5.2 The illuminating lamps described in paragraphs 2.7.9, 2.7.10 and 2.7.19 shall be so installed that correct adjustment of their orientation can easily be carried out.
- 5.3 For all light-signalling devices, including those mounted on the side panels, the reference axis of the lamp when fitted to the vehicle shall be parallel to the bearing plane of the vehicles on the road. In addition, it shall be perpendicular to the median longitudinal plane of the vehicle in the case of side retro-reflector and side marker lamps and parallel to that plane in the case of all other signalling devices. In each direction a tolerance of $\pm 3^\circ$ shall be allowed. In addition, any specific instructions as regards fitting laid down by the manufacturer shall be complied with.
- 5.4 In the absence of specific requirements, the height and alignment of the lamps shall be checked with the unladen vehicle placed on a flat, horizontal surface under normal conditions of use of a vehicle as defined in 2.24.

- 5.5 In the absence of specific requirements, lamps constituting a pair shall:
 - 5.5.1 be fitted to the vehicle symmetrically in relation to the median longitudinal plane. (this is to be based on the exterior geometrical form of the lamp and not on the edge of its illuminating surface referred in 2.9).
 - 5.5.2 be symmetrical to one another in relation to the median longitudinal plane. This requirement is not valid with regard to the interior structure of the lamp.
 - 5.5.3 satisfy the same colorimetric characteristics (component type approval value).
 - 5.5.4 have substantially identical photometric characteristics (component type approval value).
- 5.6 On vehicles whose external shape is asymmetrical, the above requirements shall be satisfied as far as possible.

5.7. Grouped, Combined or Reciprocally Incorporated Lamps

- 5.7.1 Lamps may be grouped, combined or reciprocally incorporated with one another provided that all requirements regarding colour, position, alignment, geometric visibility, electrical connections and other requirements, if any, for each lamp are fulfilled.
 - 5.7.1.1 However, where stop lamps and direction indicator lamps are grouped, any horizontal or vertical straight line passing through the projections of the apparent surfaces of these functions on a plane perpendicular to the reference axis, shall not intersect more than two borderlines separating adjacent areas of different colour.
 - 5.7.2 Where the apparent surface of a single lamp is composed of two or more distinct parts, it shall satisfy the following requirements:
 - 5.7.2.1 Either the total area of the projection of the distinct parts on a plane tangent to the exterior surface of the transparent material and perpendicular to the reference axis shall occupy not less than 60 per cent of the smallest quadrilateral circumscribing the said projection, or the distance between two adjacent / tangential distinct parts shall not exceed 15 mm when measured perpendicularly to the reference axis.
- 5.8 The maximum height with respect to the ground shall be measured from the highest point and the minimum height from the lowest point of the apparent surface in the direction of the reference axis.

In the case of dipped-beam head lamps, the minimum height shall be measured from the lowest point of the effective outlet of the optical system (eg. reflector, lens, projection lens) independent of its utilisation.

Where the maximum and minimum height clearly meets the requirements of this standard, the exact edges of any surface need not be determined.

- 5.8.1 The position, as regards width, shall be determined from the edge of the apparent surface in the direction of reference axis which is the farthest from the median longitudinal plane of the vehicle when referred to the overall width and from the inner edges of the apparent surface in the direction of reference axis when referred to the distance between the lamps.

Where the position, as regards width, clearly meets the requirements of this standard the exact edges of any surface need not be determined.

- 5.9 In the absence of specific requirements, no lamps other than direction-indicator lamps and the hazard-warning signal and amber side-marker lamps complying with paragraph 6.18.7. below, shall be flashing lamps.
- 5.10 No red light in the forward direction and no white light in the rearward direction, shall be emitted from a lamp (which could give rise to confusion), other than from a reversing lamp and a rear registration plate lamp. While considering this requirement, no account shall be taken of lighting devices fitted in the interior of the vehicle. In case of doubt, this requirement shall be verified as follows:
- 5.10.1 For the visibility of red light towards the front of a vehicle, with the exception of a red rearmost side-marker lamp, there shall be no direct visibility of the light emitting surface of a red lamp if viewed by an observer moving within zone 1 in a transverse plane situated 25 m in front of the vehicle (Ref. Fig.3).
- 5.10.2 For the visibility of white light towards the rear: There shall be no direct visibility of the light emitting surface of a white lamp if viewed by an observer moving within zone 2 in a transverse plane situated 25 m behind the vehicle (Ref. Fig.4).
- 5.10.3 In their respective planes, Zones 1 and 2 explored by eye of the observer are bounded:
- 5.10.3.1 As regards height, by two horizontal planes which are 1 m and 2.2 m respectively above the ground.
- 5.10.3.2 As regards width, by two vertical planes which, forming to the front and to the rear respectively an angle of 15° outwards from the vehicle's median longitudinal plane, pass through the point or points of contact of vertical planes parallel to the vehicle's median longitudinal plane delimiting the vehicle's overall width, If there are several points of contact, the farthest forward shall correspond to the forward plane and the one rearmost to the rearward plane.
- 5.11 The electrical connections shall be such that the front and rear position lamps end-outline marker lamps, side-marker lamps and the rear registration plate lamp wherever fitted can only be switched ON and OFF simultaneously. This condition does not apply when using front and rear position lamps as well as side-marker lamps combined or reciprocally incorporated with the said lamps as parking lamps and when side- marker lamps are permitted to flash.

- 5.12 The electrical connections shall be such that main-beam and dipped-beam headlamps and the front fog lamps can not be switched ON unless the lamps referred to in paragraph 5.11 above are also switched ON. This requirement shall not apply, however, to main-beam or dipped-beam headlamps when their luminous warning consist of the intermittent lighting up at short intervals of the main-beam headlamp/dipped-beam headlamps or the alternate lighting up at short intervals of the main-beam and dipped-beam headlamps.
- 5.13 The function of circuit closed tell-tale may be fulfilled by operational tell-tale.
- 5.14 **Concealable Lamps**
- 5.14.1 The concealment of lamps shall be prohibited with the exception of the main-beam headlamp, the dipped-beam headlamp and the front fog lamp which may be concealed when not in use.
- 5.14.2 In the event of any failure affecting the operations of the concealment device(s), the lamp shall remain in the position of use, if already in use or shall be capable of being moved into the position of use without the aid of tools.
- 5.14.3 It shall be possible to move the lamps into the position of use and switch them ON by means of a single control without excluding the possibility of moving them into the position of use without switching them ON. However in the case of grouped main-beam and dipped-beam headlamps, the control referred to above is required only to activate the dipped-beam headlamps.
- 5.14.4 It shall not deliberately be possible from the driver's seat to stop the movement of switched ON lamps before they reach the position of use. If there is a danger of dazzling other road users by the movement of the lamps they may light up only when they have reached their position of use.
- 5.14.5. When the concealment device has a temperature of -30 °C to +50 °C the headlamps shall be capable of reaching the position of use within three seconds of initial operation of the control.

5.15 The colours of the light emitted by the lamps shall be the following:

main-beam headlamp	white
dipped-beam headlamp	white
front fog lamp	white or selective yellow
reversing lamp	white
direction-indicator lamp	amber
hazard warning signal	amber
stop lamp	red
rear registration plate lamp	white
front position lamp	white
rear position lamp	red
rear fog lamp	red
parking lamp	white in front, red at the rear, amber if reciprocally incorporated in the side direction-indicator lamps or in the side-marker lamps.
side-marker lamp	amber; however the rearmost side- marker lamp can be red if it is grouped or combined or reciprocally incorporated with the rear position lamp, the rear end-outline marker lamp, the rear fog lamp, the stop lamp or is grouped or has part of the light emitting surface in common with the rear retro-reflector.
end-outline marker lamp:	white in front, red at the rear
daytime running lamp	White
rear retro-reflector, non- triangular	red
rear retro-reflector, triangular:	red
front retro-reflector, non- triangular	White or colourless
side retro-reflector, non- triangular	amber; however the rearmost side retro-reflector can be red if it is grouped or has part of the light emitting surface in common with the rear position lamp, the rear end-outline marker lamp, the rear fog lamp, the stop-lamp or the red rearmost side-marker lamp.
cornering lamp	white

- 5.16. **Number of lamps**
- 5.16.1. The number of lamps mounted on the vehicle should be equal to the number(s) specified in each of paragraphs 6.1. to 6.20.
- 5.17. Any lamp may be installed on movable components provided that the conditions specified in paragraphs 5.18., 5.19. and 5.20. are fulfilled.
- 5.18. Rear position lamps, rear direction indicator lamps and rear retro reflectors – triangular as well as non-triangular, may be installed on movable components only;
- 5.18.1. if at all fixed positions of the movable components the lamps on the movable components meet all the position, geometric visibility and photometric requirements for those lamps. Should the above functions be obtained by an assembly of two lamps marked "D" (see paragraph 2.16.1.) only one of these lamps needs to meet the above-mentioned requirements;
- or
- 5.18.2. where additional lamps for the above functions are fitted and are activated, when the movable component is in any fixed open position, provided that these additional lamps satisfy all the position, geometric visibility and photometric requirements applicable to the lamps installed on the movable component.
- 5.19. When the movable components are in a position of use other than a normal position the devices installed on them shall not cause undue discomfort to road users.
- 5.20. When a lamp is installed on a movable component and the movable component is in the normal position of use, the lamp shall always return to the position(s) specified by the manufacturer in accordance with this standard. In the case of dipped-beam headlamps and front fog lamps, this requirement shall be considered satisfied if when the movable component are moved and returned to the normal position 10 times, no value of the angular inclination of these lamps relative to its support, measured after each operation of the movable component, differs by more than 0.15 % from the average of the 10 measured values. If this value is exceeded each limit specified in paragraph 6.2.6.1.1 shall then be modified by this excess to decrease the allowed range of inclinations when checking the vehicle according Annex C.
- 5.21. The apparent surface in the direction of the reference axis of front and rear position lamps, front and rear direction-indicator lamps and retro-reflectors shall not be hidden more than 50 per cent by any movable component, with or without a light-signalling device installed on it, in any fixed position different from the "normal position of use". If the above requirement is not practicable:
- 5.21.1. additional lamps satisfying all the position, geometric visibility and photometric requirements for the above indicated lamps shall be activated when the apparent surface in the direction of the reference

axis of these lamps is more than 50 per cent hidden by the movable component; or

- 5.21.2. a remark in the technical information to be submitted by the vehicle manufacturer / test report (see paragraph 7.0) shall inform other Administrations that more than 50 percent of the apparent surface in the direction of the reference axis can be hidden by the movable components; and a notice in the vehicle shall inform the user that in certain position(s) of the movable components other road users shall be warned of the presence of the vehicle on the road; for example by means of a warning triangle or other devices according to national requirements for use on the road.
- 5.21.3. Paragraph 5.21.2 does not apply to retro-reflectors.
- 5.22. With the exception of retro-reflectors, a lamp even type approved is deemed not to be present when it cannot be made to operate by the sole installation of a light source.
- 5.23. Lamps shall be fitted in a vehicle in such a way that the light source can be correctly replaced according to the instructions of the vehicle manufacturer without the use of special tools, other than those provided with the vehicle by the manufacturer. This requirement is not applicable to:
 - (a) devices approved with a non-replaceable light source;
 - (b) devices approved with light sources according to AIS-034.
- 5.24. Any temporary fail-safe replacement of the light-signaling function of a rear position lamp is allowed, provided that the substituting function in case of a failure is similar in colour, main intensity and position to the function that has ceased to operate and provided that the substituting device remains operational in its original safety function. During substitution, a tell-tale on the dashboard (see paragraph 2.18. of this standard) shall indicate occurrence of a temporary replacement and need for repair.

6.0 INDIVIDUAL SPECIFICATIONS

6.1 Main-beam Headlamp

- 6.1.1 **Presence:** Mandatory on all motor vehicles of category M and N. Prohibited on trailers.
- 6.1.2 **Number:** Two or four.

For vehicles of the category N₃: Two extra main-beam headlamps may be installed.

Where a vehicle is fitted with four concealable headlamps, the installation of two additional headlamps shall only be authorised for the purpose of light-signalling, consisting of intermittent illumination at short intervals (see paragraph 5.12) in daylight.

- 6.1.3 **Arrangement:** No individual specifications.
- 6.1.4 **Position:**
 - 6.1.4.1 **Width:** No individual specifications.
 - 6.1.4.2 **Height:** No individual specifications
 - 6.1.4.3 **Length:** At the front of the vehicle and fitted in such a way that the light emitted does not cause discomfort to the driver either directly or indirectly through the rear-view mirrors and/or other reflecting surfaces of the vehicle.
- 6.1.5 **Geometric Visibility**

The visibility of the illuminating surface, including its visibility in areas which do not appear to be illuminated in the direction of observation considered shall be ensured within a divergent space defined by generating lines based on the perimeter of the illuminating surface and forming an angle of not less than 5 degrees with the axis of reference of the headlamp. The origin of the angles of geometric visibility is the perimeter of the projection of the illuminating surface on a transverse plane tangent to the foremost part of the lens of the headlamp.
- 6.1.6 **Orientation:** Towards the front.
 - 6.1.6.1 Not more than one main-beam head lamp on each side of the vehicle may swivel to produce bend lighting.
- 6.1.7 **Electrical Connection**
 - 6.1.7.1 The main-beam headlamps may be switched ON either simultaneously or in pairs. In case the extra two main-beam headlamps are installed, as permitted under paragraph 6.1.2. for vehicles of the category N₃ only, no more than two pairs may be simultaneously lit. For changing over from the dipped to the main-beam at least one pair of main-beam headlamps shall be switched ON. For changing over from the main-beam to the dipped-beam, all main-beam headlamps shall be switched OFF simultaneously.
 - 6.1.7.2 The dipped-beams may remain switched ON at the same time as the main-beams.
 - 6.1.7.3 Where four concealable headlamps are fitted, their raised position shall prevent the simultaneous operation of any additional headlamps fitted, if these are intended to provide light signals consisting of intermittent illumination at short intervals (Ref. paragraph 5.12) in daylight.
- 6.1.8 **Tell-tale :** Circuit closed tell-tale is mandatory

6.1.9 Other Requirements

6.1.9.1. The aggregate maximum intensity of the main-beam headlamps which can be switched ON simultaneously shall not exceed 225,000 cd (component type approval value) which corresponds to a reference value of 75.

6.1.9.2. This maximum intensity shall be obtained by adding together the individual reference marks which are indicated on the headlamps. The reference mark shall be given to each of the headlamp as per AIS-012.

6.2 Dipped-beam Headlamp

6.2.1. **Presence:** Mandatory on motor vehicles. Prohibited on trailers.

6.2.2. **Number:** Two

6.2.3. **Arrangement:** No special requirement.

6.2.4. **Position:**

6.2.4.1. **Width:** That edge of the apparent surface in the direction of the reference axis which is farthest from the vehicle's median longitudinal plane shall be not more than 400 mm from the extreme outer edge of the vehicle. The inner edges of the apparent surfaces in the direction of the reference axes shall be not less than 600 mm apart. This does not apply, however, for M₁ and N₁ Category vehicles; for all other categories of motor vehicles. This distance may be reduced to 400 mm where the overall width of the vehicle is less than 1,300 mm.

6.2.4.2. **In height:** not less than 500 mm and not more than 1,200 mm above the ground. For category N₃G (off-road) vehicles (as defined in AIS-053) the maximum height may be increased to 1,500 mm.

6.2.4.3. **Length:** At the front of the vehicle. This requirement shall be deemed to be satisfied if the light emitted does not cause discomfort to the driver either directly, or indirectly through the rear view mirrors and / or other reflecting surfaces of the vehicle.

6.2.5 Geometric Visibility

6.2.5.1. Defined by angles α and β as specified in 2.13.

6.2.5.2. α = 15 degrees upwards and 10 degrees downwards.

6.2.5.3. β = 45 degrees outwards and 10 degrees inwards.

6.2.5.4. Since the photometric values required for dipped-beam headlamps do not cover the full geometric field of vision, a minimum value of 1 cd in the space remaining is required for type approval purposes. The presence of partitions or other items of equipment near the headlamp shall not give rise to secondary effects causing discomfort to other road users.

6.2.6 **Orientation:** Towards the front.

6.2.6.1 **Vertical Orientation**

6.2.6.1.1 The initial downward inclination of the cut-off of the dipped-beam to be set in the unladen condition of the vehicle with one person in the driver's seat shall be specified within an accuracy of 0.1% by the manufacturer and indicated in a clearly legible and indelible manner on each vehicle close to either headlamps or the manufacture's plate by the symbol shown in Annex A. The value of this indicated downward inclination shall be defined in paragraph 6.2.6.1.2.

6.2.6.1.2 Depending on the mounting height in meters (h) of the lower edge of the apparent surface in the direction of the reference axis of the dipped-beam headlamp, measured on the unladen vehicle, the vertical inclination of the cut-off of the dipped-beam shall, under all the static conditions of Annex.B, remain between the following limits and the initial aiming shall have the following values (summarised in Fig.5 below):

$$h < 0.8$$

limits: between -0.5 per cent and -2.5 per cent

initial aiming: between -1.0 per cent and -1.5 per cent

$$0.8 \leq h \leq 1.0$$

limits: between -0.5 per cent and -2.5 per cent

initial aiming: between -1.0 per cent and -1.5 per cent

or, at the discretion of the manufacturer,

limits: between -1.0 per cent and -3.0 per cent

initial aiming: between -1.5 per cent and -2.0 per cent

The application for the vehicle type-approval shall, in this case, contain information as to which of the two alternatives is to be used.

$$h > 1.0$$

limits: between -1.0 per cent and -3.0 per cent

initial aiming: between -1.5 per cent and -2.0 per cent

The above limits and the initial aiming values are summarized in the diagram below.

For category N₃G (off-road) vehicles where the headlamps exceed a height of 1,200 mm, the limits for the vertical inclination of the cut-off shall be between: -1.5 per cent and -3.5 per cent.

The initial aim shall be set between: -2 per cent and -2.5 per cent.

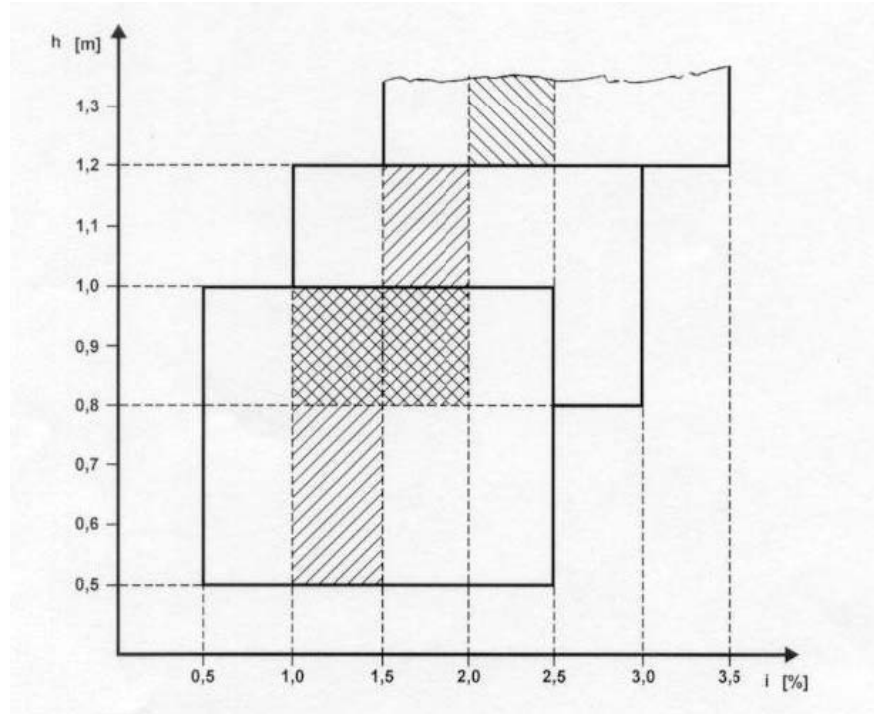

6.2.6.2. Headlamp levelling device

6.2.6.2.1 In the case where a headlamp levelling device is necessary to satisfy the requirements of paragraphs 6.2.6.1.1 and 6.2.6.1.2, the device shall be automatic.

6.2.6.2.2 However, devices which are adjusted manually, either continuously or non-continuously shall be permitted, provided they have a stop position at which the lamps shall be returned to the initial inclination defined in paragraph 6.2.6.1.1 by means of the usual adjusting screws or similar means. These manually adjustable devices shall be operable from the driver's seat.

Continually adjustable devices shall have reference marks indicating the loading conditions that require adjustment of the dipped-beam.

The number of positions on devices which are not continuously adjustable shall be such as to ensure compliance with the range of values prescribed in paragraph 6.2.6.1.2 in all the loading conditions defined in Annex B.

For these devices also, the loading conditions of Annex B that require adjustment of the dipped-beam shall be clearly marked near the control of the device (Ref. Annex D).

6.2.6.2.3 In the event of failure of the devices described in paragraphs 6.2.6.2.1 and 6.2.6.2.2, the dipped-beam shall not assume a position in which the dip is less than that it was at the time when the failure of the device occurred.

6.2.6.3 **Measuring Procedure:**

- 6.2.6.3.1 After adjustment of initial inclination, the vertical inclination of the dipped-beam, expressed in % shall be measured in static conditions under the loading conditions defined in Annex B.
- 6.2.6.3.2 The measurement of the variation of the dipped-beam as a function of load shall be carried out in accordance with the test procedure given in Annex C.
- 6.2.6.4. Horizontal orientation

The horizontal orientation of one or both dipped-beam headlamps may be varied to produce bend lighting, provided that if the whole beam or the kink of the elbow of the cut-off is moved, the kink of the elbow of the cut-off shall not intersect the line of the trajectory of the centre of gravity of the vehicle at distances from the front of the vehicle which are larger than 100 times the mounting height of the respective dipped-beam headlamps.

6.2.7 **Electrical Connections:**

The control for changing over to the dipped-beam shall switch OFF all main-beam headlamps simultaneously. The dipped-beam may remain switched ON at the same time as the main-beam.

In the case of dipped-beam headlamps according to AIS-034 the gas-discharge light sources shall remain switched on during the main-beam operation.

One additional light source, located inside the dipped-beam headlamps or in a lamp (except the main-beam headlamp) grouped or reciprocally incorporated with the respective dipped-beam headlamps, may be activated to produce bend lighting, provided that the horizontal radius of curvature of the trajectory of the centre of gravity of the vehicle is 500 m or less. This may be demonstrated by the manufacturer by calculation or by other means accepted by the authority responsible for type approval.

Dipped-beam headlamps may be switched ON or OFF automatically. However, it shall be always possible to switch these dipped-beam headlamps ON and OFF manually.

6.2.8 **Tell-tale:** Optional.

However, in the case where the whole beam or the kink of the elbow of the cut-off is moved to produce bend lighting, an operational tell-tale is mandatory; it shall be a flashing warning light which comes on in the event of a malfunction of the displacement of the kink of the elbow of the cut-off.

- 6.2.9 **Other Requirements:** The requirements of 5.5.2 shall not apply to dipped-beam headlamp.

Dipped-beam headlamps with a light source having an objective luminous flux which exceeds 2,000 lumen shall only be installed in conjunction with the installation of headlamp cleaning device(s) according to AIS-083. In addition, with respect to vertical inclination, the provisions of paragraph 6.2.6.2.2. above shall not be applied.

Certifying agency can still prohibit the use of mechanical cleaning systems when headlamps with plastic lenses, marked "PL", are installed.

Only dipped-beam headlamps according to AIS-012 may be used to produce bend lighting.

If bend lighting is produced by a horizontal movement of the whole beam or the kink of the elbow of the cut-off, it shall be activated only if the vehicle is in forward motion; this shall not apply if bend lighting is produced for a left turn in left hand traffic.

6.3 **Front Fog Lamp:**

- 6.3.1 **Presence:** Optional on motor vehicles, prohibited on trailers.

- 6.3.2 **Number:** Two.

- 6.3.3 **Arrangement:** No special requirement.

6.3.4 **Position**

- 6.3.4.1 **Width:** That point on the apparent surface in the direction of the reference axis which is farthest from the vehicle's median longitudinal plane shall not be more than 400 mm from the extreme outer edge of the vehicle.

Height: Minimum: Not less than 250 mm above the ground.
Maximum: For M₁ and N₁ category vehicles not more than 800 mm above the ground. For all other categories of vehicles no maximum height.

However, no point on the apparent surface in the direction of the reference axis shall be higher than the highest point on the apparent surface in the direction of the reference axis of the dipped-beam headlamp.

- 6.3.4.2 **Length:** At the front of the vehicle. This requirement shall be deemed to be satisfied if the light emitted does not cause discomfort to the driver either directly, or indirectly through the rear-view mirrors and / or other reflecting surfaces of the vehicle.

6.3.5 **Geometric Visibility:**

Defined by angles α and β as specified in 2.13;

α = 5 degrees upwards and downwards,
 β = 45 degrees outwards and 10 degrees inwards.

6.3.6 **Orientation:** Towards the front. The alignment of the front fog lamps shall not vary according to the angle of lock of steering.

They shall be directed forward without causing undue dazzle or discomfort to oncoming drivers and other road users.

6.3.7 **Electrical Connections:** It shall be possible to switch the front fog lamps ON and OFF independently of the main-beam headlamps, dipped-beam headlamps or any combination of main and dipped-head lamps.

6.3.8 **Tell-tale:** Circuit closed tell-tale mandatory. An Independent non-flashing warning light

6.3.9 **Other Requirements:** None.

6.4 **Reversing Lamp**

6.4.1 **Presence:** Mandatory on motor vehicles and on trailers of categories T₂, T₃ and T₄. Optional on trailers of category T₁.

6.4.2 **Number:**

6.4.2.1. One device mandatory and a second device optional on motor vehicles of category M₁ and on all other vehicles with a length not exceeding 6,000 mm.

6.4.2.2 Two devices mandatory and two devices optional on all vehicles with a length exceeding 6,000 mm, except vehicles of category M₁.

6.4.3 **Arrangement:** No special requirement.

6.4.4. **Position:**

6.4.4.1 **Width:** No special requirement.

6.4.4.2 **Height:** Not less than 250 mm and not more than 1,200 mm above the ground.

6.4.4.3 **Length:** At the rear of the vehicle.

However, if installed, the two optional devices mentioned in paragraph 6.4.2.2. shall be fitted on the side or rear of the vehicle, in conformity with the requirements of paragraphs 6.4.5. and 6.4.6.

6.4.5 **Geometric Visibility:**

Defined by angles α and β as specified in 2.13;

α = 15 degrees upwards and 5 degrees downwards

β = 45 degrees to right and to left if there is only one light

45 degrees outwards and 30 degrees inwards if there are two.

The reference axis of the two optional devices mentioned in paragraph 6.4.2.2, if fitted on the side of the vehicle shall be oriented sideward horizontally with an inclination of $10^\circ \pm 5^\circ$ in relation to the median longitudinal plane of the vehicle.

6.4.6 **Orientation**

Rearwards.

In the case of the two optional devices mentioned in paragraph 6.4.2.2., if fitted on the side of the vehicle, the above-mentioned requirements of paragraph 6.4.5. shall not be applied. However, the reference axis of these devices shall be orientated outwards not more than 15° horizontally towards the rear in relation to the median longitudinal plane of the vehicle.

6.4.7 **Electrical Connections**

6.4.7.1 They shall be such that the lamp can light up only if the reverse gear is engaged and if the device which controls the starting and stopping of the engine is in such a position that operation of the engine is possible. It shall not light up or remain lit if either of the above conditions is not satisfied.

6.4.7.2. Moreover, the electrical connections of the two optional devices mentioned in paragraph 6.4.2.2. shall be such that these devices cannot illuminate unless the lamps referred to in paragraph 5.11. are switched on. It is allowed to switch on the devices fitted on the side of the vehicle, for slow manoeuvres in forward motion. For such purposes, the devices shall be activated and deactivated manually by a separate switch and may remain illuminated even when reverse gear is disengaged. However, if the forward speed of the vehicle exceeds 10 km/h the devices shall be switched off automatically and shall remain switched off until deliberately switched on again.

6.4.8 Tell-Tale: Optional.

6.4.9 **Other Requirements:** None.

6.5 **Direction-Indicator Lamp**

6.5.1 **Presence:** Mandatory (See figure below)

Different categories of direction indicator lamps viz. 1, 1a, 1b, 2a, 2b, 5 and 6 (as defined in AIS-012) are shown in Fig.6. The assembly of which on one vehicle constitutes an arrangement ("A" and "B").

Arrangement 'A' shall apply to all motor vehicles.

Arrangement 'B' shall apply to trailers only.

6.5.2 **Number:** According to the arrangement.

6.5.3. Arrangements (Ref. Fig. 6).

For all motor vehicles of category M and N:

Two front direction indicator lamps of the following categories:

- 1 or 1a or 1b, if the distance between the edge of the apparent surface in the direction
- of the reference axis of this lamp and that of the apparent surface in the direction of the reference axis of the dipped-beam headlamp and/or the front fog lamp, if there is one, is at least 40 mm;

1a or 1b, if the distance between the edge of the apparent surface in the direction of the reference axis of this lamp and that of the apparent surface in the direction of the reference axis of the dipped-beam headlamp and/or the front fog lamp, if there is one, is greater than 20 mm and less than 40 mm;

1b, if the distance between the edge of the apparent surface in the direction of the reference axis of this lamp and that of the apparent surface in the direction of the reference axis, of the dipped-beam headlamp and/or the front fog lamp, if there is one, is less than or equal to 20 mm;

two rear direction indicator lamps of categories 2a or 2b.

two optional lamps (Category 2a or 2b) on all vehicles in categories M₂, M₃, N₂, N₃

two side direction-indicator lamps of the categories 5 or 6 (minimum requirements):

5

for all M₁ vehicles;

for N₁, M₂ and M₃ vehicles not exceeding 6 metres in length.

6

for all N₂ and N₃ vehicles;

for N₁, M₂ and M₃ vehicles exceeding 6 metres in length.

It is permitted to replace category 5 side direction-indicator lamps by category 6 side direction-indicator lamps in all instances.

Where lamps combining the functions of front direction-indicator lamps (categories 1, 1a, 1b) and side direction-indicator lamps (categories 5 or 6) are fitted, two additional side direction-indicator lamps (categories 5 or 6) may be fitted to meet the visibility requirements of paragraph 6.5.5.

B: Two rear direction-indicator lamps (categories 2a or 2b).

two optional lamps (category 2a or 2b) on all vehicles in categories T₂, T₃ and T₄.

6.5.4 Position

6.5.4.1. **Width:** The edge of the apparent surface in the direction of the reference axis farthest from the median longitudinal plane of the vehicle shall not be more than 400 mm from the extreme outer edge of the vehicle. This condition shall not apply to optional rear lamps. The distance between the inner edges of the two apparent surfaces in the direction of the reference axes shall not be less than 600 mm. This distance may be reduced to 400 mm where the overall width of the vehicle is less than 1,300 mm.

6.5.4.2 **Height:** Above the ground.

6.5.4.2.1. The height of the light-emitting surface of the side direction-indicator lamps of categories 5 or 6 shall not be:

less than: 350 mm for M_1 and N_1 category of vehicles, and 500 mm for all other categories of vehicles, both measured from the lowest point; and more than: 1,500 mm, measured from the highest point.

6.5.4.2.2 The height of the direction indicator lamps of categories 1, 1a, 1b, 2a and 2b, measured in accordance with paragraph 5.8, shall not be less than 350 mm or more than 1,500 mm.

6.5.4.2.3 If the structure of the vehicle does not permit these upper limits, measured as specified above, to be respected, and if the optional lamps not installed, they may be increased to 2,300 mm for side direction indicator lamps of category 5, and 6 and to 2,100 mm for the direction indicator lamps of categories 1, 1a, 1 b, 2a and 2b.

6.5.4.2.4. If optional lamps are installed, they shall be placed at a height compatible with the applicable requirements of paragraph 6.5.4.1., the symmetry of the lamps, and at a vertical distance as large as the shape of the bodywork makes it possible, but not less than 600 mm above the mandatory lamps.

6.5.4.3 **Length (Ref. Fig. 6):**

The distance between the light-emitting surface of the side direction indicator lamp (categories 5 and 6) and the transverse plane which marks the forward boundary of the vehicle's overall length, shall not exceed 1,800 mm. If the structure of the vehicle makes it impossible to comply with the minimum angles of visibility, this distance may be increased to 2,500 mm.

6.5.5 Geometric Visibility

6.5.5.1. Horizontal angles (Refer Figure 6 below).

Vertical angles: 15° above and below the horizontal for direction – indicator lamps of categories 1, 1a, 1b, 2a, 2b and 5. The vertical angle below the horizontal may be reduced to 5° if the lamps are less than 750 mm above the ground; 30° above and 5° below the horizontal for direction indicators lamps of category 6. The vertical angle above the horizontal may be reduced to 5° if the optional lamps are not less than 2,100mm above the ground.

ARRANGEMENT ^{1/}

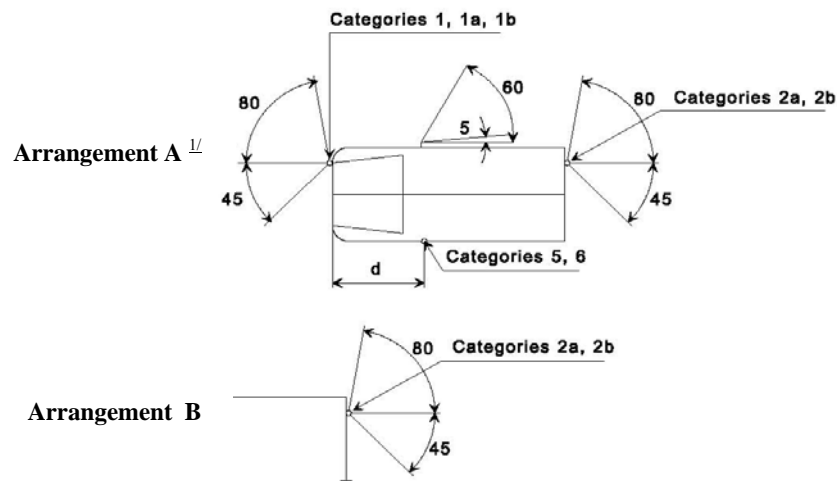

Figure 6

6.5.5.2. or, at the discretion of the manufacturer, for M₁ and N₁ category vehicles ^{2/}:

Note: ^{1/} The value of 5° given for dead angle of visibility to the rear of the side direction-indicator is an upper limit. d ≤ 1.80 m (for M1 and N1 category vehicles d ≤ 2.50 m).

^{2/} The value of 5° given for the dead angle of visibility to the rear of the side direction-indicator is an upper limit d ≤ 2.50 m.

**Front and rear direction lamps, as well as side marker lamps;
Horizontal angles see figure below:**

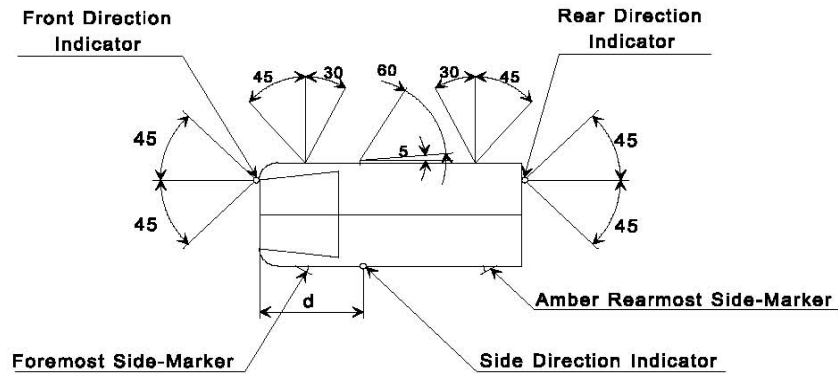

- 6.5.6 **Orientation:** According to the specifications for installation by the manufacturer, if any.
- 6.5.7 **Electrical Connections:** Direction indicator lamps shall be switched ON independently of other lamps. All direction indicator lamps on one side of a vehicle shall be switched ON and OFF by means of one control and shall flash in phase.

On M_1 and N_1 vehicles less than 6 m in length, with an arrangement complying with paragraph 6.5.5.2. above, the amber side-marker lamps, when mounted, shall also flash at the same frequency (in phase) with the direction indicator lamps.

6.5.8 **Tell-tale**

Operating tell-tale is mandatory for front and rear direction indicator lamps. It may be visual or auditory or both. If it is visual, it shall be a flashing light which, at least in the event of the malfunction of any of the front or rear direction indicator lamps, is either extinguished, or remains alight without flashing, or shows a marked change of frequency. If it is entirely auditory, it shall be clearly audible and shall show a marked change of frequency, at least in the event of the malfunction of any of the front or rear direction indicator lamps.

If a motor vehicle is equipped to draw a trailer, it shall be fitted with a special visual operational tell-tale for the direction indicator lamps on the trailer unless the tell-tale of the drawing vehicle allows the failure of any one of the direction indicator lamps on the vehicle combination thus formed to be detected.

For the optional pair of direction – indicator lamps on trailers, operating tell-tale shall not be mandatory.

6.5.9 **Other Requirements**

The light shall be a flashing light, flashing at 90 ± 30 times per minute. Operation of the light-signal control shall be followed within not more than one second by the emission of light and within not more than one and one-half seconds by its first extinction.

If a motor vehicle is equipped to draw a trailer, the control of the direction indicator lamps on the drawing vehicle shall also operate the indicator lamps of the trailer. In the event of failure, other than short-circuit, of one direction indicator lamp, the others shall continue to flash but the frequency in this condition may be different from that prescribed.

6.6 **Hazard Warning Signal**

6.6.1 **Presence** : Mandatory.

The signal shall be given by simultaneous operation of the direction-indicator lamps in accordance with the requirements of paragraph 6.5 above.

6.6.2 **Number** : As specified in paragraph 6.5.2.

6.6.3 **Arrangements** : As specified in paragraph 6.5.3.

6.6.4 **Position**

6.6.4.1 **Width** : As specified in paragraph 6.5.4.1.

6.6.4.2 **Height** : As specified in paragraph 6.5.4.2.

6.6.4.3 **Length** : As specified in paragraph 6.5.4.3.

6.6.5 **Geometric Visibility**: As specified in paragraph 6.5.5.

6.6.6 **Orientation**: As specified in paragraph 6.5.6.

6.6.7 **Electrical Connections**: The signal shall be operated by means of a separate control enabling all the direction indicator lamps flash in phase.

On M_1 and N_1 vehicles less than 6 m in length, with an arrangement complying with paragraph 6.5.5.2. above, the amber side-marker lamps, when mounted, shall also flash at the same frequency (in phase) with the direction indicator lamps.

6.6.8 **Tell-tale**: Circuit closed tell-tale is mandatory. It shall be flashing warning light, which can operate in conjunction with the tell-tales specified in paragraph 6.5.8.

6.6.9 **Other Requirements:**

If a power driven vehicle is equipped to draw a trailer, the hazard warning signal control shall also be capable of bringing the direction indicator lamps on the trailer into action. The hazard warning signal shall be able to function even if the device which starts or stops the engine is in a position which makes it impossible to start the engine.

6.7 **Stop Lamp**

6.7.1 **Presence :**

6.7.1.1 Devices of S1 or S2 Categories (as defined in AIS-012): Mandatory on all M and N categories of vehicles.

6.7.1.2 Devices of S3 category: mandatory on M₁ and N₁ category of vehicles with full metal body; except for chassis-cabs and those N₁ category vehicles with open cargo space;

optional on other categories of vehicles.

6.7.2 **Number**

Two devices of S1 or S2 and one device of S3 when fitted:

6.7.2.1. Except the case where category S3 device is installed, two optional category S1 or S2 devices may be installed on vehicles in categories M₂, M₃, N₂, N₃, T₂, T₃, and T₄.

6.7.2.2 Only, when the median longitudinal plane of the vehicle (Ref. IS:9435 - 2004) is not located on a fixed body panel but on one or two movable parts of the vehicle (e.g. doors), and lacks sufficient space to install a single device of the S3 Category on the median longitudinal plane above such movable parts, either two devices of the S3 category type 'D' may be installed, or any device of S3 category may be installed offset to the left or right of the median longitudinal plane.

6.7.3 **Arrangement:** No special requirement

6.7.4 **Position**

6.7.4.1 **Width:** For M₁ and N₁ category vehicles: For S1 or S2 categories devices that point on the apparent surface in the direction of the reference axis which is farthest from the vehicle's median longitudinal plane shall not be more than 400 mm from the extreme outer edge of the vehicle;

For the distance in between the inner edges of the apparent surfaces in the direction of the reference axes there is no special requirement.

For all other categories of vehicles: For S1 or S2 categories devices the distance in between the inner edges of the apparent surfaces in the direction of the reference axes shall be not less than 600 mm.

This distance may be reduced to 400 mm if the overall width of the vehicle is less than 1,300 mm.

For S3 Category devices: The centre of reference shall be situated on the median longitudinal plane of the vehicle. However, in the case where the two devices of the S3 Category are installed, according to paragraph 6.7.2, they shall be positioned as close as possible to the median longitudinal plane - one on each side of this plane. In the case where one S3 Category lamp offset from the median longitudinal plane is permitted according to paragraph 6.7.2., this offset shall not exceed 150 mm from the median longitudinal plane to the centre of reference of the lamp.

6.7.4.2 Height

6.7.4.2.1 For S1 or S2 Category devices: Above the ground, not less than 350 mm and not more than 1,500 mm. (2,100 mm. if the shape of the bodywork makes it impossible to keep within 1,500 mm and if the optional lamps are not installed.

If the optional lamps are installed, they shall be positioned at a height compatible with the requirements of the width and the symmetry of the lamps, and at a vertical distance as large as the shape of the bodywork makes it possible, but not less than 600 mm above the mandatory lamps).

6.7.4.2.2 For S3 Category devices, the horizontal plane tangential to the lower edge of the apparent surface shall either :

(a) either not be more than 150 mm below the horizontal plane tangential to the lower edge of the exposed surface of the glass or glazing of the rear window, or

(b) not be less than 850 mm above the ground.

However, the horizontal plane tangential to the lower edge of the apparent surface of S3 category device shall be above the horizontal plane tangential to the upper edge of the apparent surface of S1 or S2 categories devices.

6.7.4.3 Length

For S1 or S2 categories devices: at the rear of the vehicle.

For S3 Category devices: no special requirement.

6.7.5 Geometric Visibility

Horizontal angle For S1 or S2 Categories devices: 45 degrees to the left and right of the longitudinal axis of the vehicle;

For S3 Category devices: 10 degrees to the left and right of the longitudinal axis of the vehicle;

Vertical angle For S1 or S2 Categories devices: 15 degrees above and below the horizontal. However, the vertical angle below the horizontal may be reduced to 5 degrees, if the height of the lamp is less than 750 mm. The vertical angle above the horizontal may be reduced to 5° in the case of optional lamps not less than 2,100 mm above the ground;

For S3 Category devices: 10 degrees above and 5 degrees below the horizontal.

6.7.6. Orientation

Towards the rear of the vehicle.

6.7.7 **Electrical Connections:** These shall light up when the service brake is Applied. The stop lamps need not function if the device which starts and/or stops the engine is in a position which makes it impossible for the engine to operate. The stop lamps may be activated by the application of a retarded or a similar device.

6.7.8 **Tell-tale:** Tell-tale is optional. Where fitted, this tell-tale shall be an operating tell-tale, consisting of non-flashing warning light which comes on in the event of the malfunctioning of the stop lamps.

6.7.9 Other Requirements

6.7.9.1 The S3 category device shall not be reciprocally incorporated with any other lamp.

6.7.9.2 The S3 category device shall be installed outside or inside the vehicle. In the case where it is installed inside the vehicle, the light emitted shall not cause discomfort to the driver through the rear-view mirrors and/or other surfaces of the vehicle (i.e. rear window).

6.8 Rear Registration Plate (Mark) Illumination Lamp

6.8.1 **Presence :** Mandatory.

6.8.2 The number, arrangement, position, geometric visibility and orientation of the device shall be such that the area of registration plate shall be adequately illuminated.

6.8.3 **Electrical Connections:** Same as paragraph 5.11.

6.8.4 **Tell-tale:** Tell-tale is optional. If it exists, its function shall be carried out by the tell-tale required for the front and rear position lamps.

6.8.5 **Other Requirements :** When the rear registration plate lamp is combined with the rear position lamp, reciprocally incorporated in the stop lamp or in the rear fog lamp, the photometric characteristics of the rear registration plate lamp may be modified during the illumination of the stop lamp or the rear fog lamp.

6.9 **Front Position Lamp**

6.9.1 **Presence :** Mandatory on all motor vehicles and on trailers over 1,600 mm wide. Optional on trailers which are not more than 1,600 mm wide.

6.9.2 **Number :** Two.

6.9.3 **Arrangement :** No special requirement.

6.9.4 **Position :**

6.9.4.1 **Width :** That point on the apparent surface in the direction of the reference axis which is farthest from the vehicle's median longitudinal plane shall not be more than 400 mm from the extreme outer edge of the vehicle. In the case of a trailer, the point on the apparent surface in the direction of the reference axis which is farthest from the median longitudinal plane shall not be more than 150 mm from the extreme outer edge of the vehicle.

The distance between the inner edges of the two apparent surfaces in the direction of the reference axes shall:

For M₁ and N₁ Category vehicles: have no special requirement;

For all other category of vehicles : be not less than 600 mm.

This distance may be reduced to 400 mm where the overall width of the vehicle is less than 1,300 mm.

6.9.4.2 **Height:** Above the ground not less than 350 mm and not more than 1,500 mm (2,100 mm for T1 and T2 categories of vehicles or if for any other categories of vehicles the shape of the bodywork makes it impossible to keep within 1,500 mm).

6.9.4.3 **Length :** No individual specification.

6.9.4.4 Where the front position lamp and another lamp are reciprocally incorporated, the apparent surface in the direction of the reference axis of the other lamp shall be used to verify compliance with the positioning requirements (paragraphs 6.9.4.1 to 6.9.4.3).

6.9.5 **Geometric Visibility**

6.9.5.1 **Horizontal angle** : 45 degrees inwards and 80 degrees outwards. In the case of trailers, the angle inwards may be reduced to 5 degrees.

Vertical angle : 15 degrees above and below the horizontal. The vertical angle below the horizontal may be reduced to 5 degrees in the case of lamps less than 750 mm above the ground.

6.9.5.2. For M₁ and N₁ category vehicles, as an alternative to paragraph 6.9.5.1., at the discretion of the manufacturer or his duly accredited representative, and only if a front side-marker lamp is installed on the vehicle.

Horizontal angle: 45° outwards to 45° inwards.

Vertical angle: 15 degrees above and below the horizontal. The vertical angle below the horizontal may be reduced to 5 degrees in the case of lamps less than 750 mm above the ground.

To be considered visible, the lamp shall provide an unobstructed view of the apparent surface of at least 12.5 square centimeters. The illuminating surface area of any retro-reflector that does not transmit light shall be excluded.

6.9.6 **Orientation** : Forwards.

6.9.7 **Electrical Connections** : Same as paragraph 5.11.

6.9.8 **Tell-tale** : Circuit-closed tell-tale is mandatory. This tell-tale shall be non-flashing and shall not be required if the instrument panel lighting can only be turned ON simultaneously with the front position lamps.

6.9.9 **Other Requirements** : If one or more infrared radiation generator(s) is (are) installed inside the front position lamp, it (they) is (are) allowed to be activated only when the headlamp on the same side of the vehicle is switched on and the vehicle is in forward motion. In the event that the front position lamp or the headlamp on the same side fails, the infrared radiation generator(s) shall be automatically switched off.

6.10 **Rear Position Lamp**

6.10.1 **Presence** : Mandatory.

6.10.2 **Number** : Two.

6.10.2.1. Except the case where end-outline marker lamps are installed, two optional position lamps may be installed on all vehicles in categories M₂, M₃, N₂, N₃, T₂, T₃, and T₄.

6.10.3 **Arrangement:** No special requirement.

6.10.4 **Position**

6.10.4.1 **Width**

That point on the apparent surface in the direction of the reference axis which is farthest from the vehicle's median longitudinal plane shall not be more than 400 mm from the extreme outer edge of the vehicle. This condition shall not apply to the optional rear lamps.

The distance between the inner edges of the apparent surfaces in the direction of the reference axes shall for M₁ and N₁ category vehicles: have no special requirement.

For all other categories of vehicles not be less than 600 mm. This distance may be reduced to 400 mm if the overall width of the vehicle is less than 1,300 mm.

6.10.4.2 **Height:** above the ground, not less than 350 mm nor more than 1,500 mm (2,100 mm if the shape of the bodywork makes it impossible to keep within 1,500 mm and if the optional lamps are not installed. If the optional lamps are installed, they shall be placed at a height compatible with the applicable requirements of paragraph 6.10.4.1., the symmetry of the lamps, and at a vertical distance as large as the shape of the bodywork makes it possible, but not less than 600 mm above the mandatory lamps).

6.10.4.3 **Length :** At the rear of the vehicle.

6.10.5 **Geometric Visibility**

6.10.5.1 **Horizontal angle:** 45 degrees inwards and 80 degrees outwards.

Vertical angle: 15 degrees above and below the horizontal. The vertical angle below the horizontal may be reduced to 5 degrees in the case of lamps less than 750 mm above the ground.

The vertical angle above the horizontal may be reduced to 5° in the case of optional lamps not less than 2,100 mm above the ground.

6.10.5.2. For M₁ and N₁ category vehicles, as an alternative to paragraph 6.10.5.1., at the discretion of the manufacturer or his duly accredited representative, and only if a rear side-marker lamp is installed on the vehicle.

Horizontal angle: 45° outwards to 45° inwards.

Vertical angle: 15° above and below the horizontal. The vertical angle below the horizontal may be reduced to 5° if the lamps are less than 750 mm above the ground.

To be considered visible, the lamp shall provide an unobstructed view of the apparent surface of at least 12.5 square centimetres. The illuminating surface area of any retro-reflector that does not transmit light shall be excluded.

- 6.10.6 **Orientation** : Rearwards.
- 6.10.7 **Electrical Connections** : Same as paragraph 5.11.
- 6.10.8 **Tell-tale** : Circuit closed tell-tale is mandatory. It shall be combined with that of the front position lamps.
- 6.10.9 **Other Requirements** : None.
- 6.11 **Rear Fog Lamp:**
- 6.11.1 **Presence** : Optional
- 6.11.2 **Number** : One or two.
- 6.11.3 **Arrangement** : No special requirement.
- 6.11.4 **Position** :
- 6.11.4.1 **Width** : If there is only one rear fog lamp, it shall be on the right side of the median longitudinal plane of the vehicle to the direction of traffic. The centre of reference may also be situated on the median longitudinal plane of the vehicle.
- 6.11.4.2 **Height** : Not less than 250 mm and not more than 1000 mm above the ground. For Category N₃G (off – road) vehicles, the maximum height may be increased to 1200 mm.
- 6.11.4.3 **Length** : At the rear of the vehicle.
- 6.11.5 **Geometric Visibility**
 Defined by angles α and β as specified in 2.13;
 α = 5 degrees upwards and 5 degrees downwards;
 β = 25 degrees to right and to left.
- 6.11.6 **Orientation** : Rearwards.
- 6.11.7 **Electrical Connections** : These shall be such that;
- 6.11.7.1 The rear fog lamp(s) cannot be switched ON unless the main-beam, dipped-beam or front fog lamps are lit;
- 6.11.7.2 The rear fog lamp(s) can be switched OFF independently of any other lamp;
- 6.11.7.3 Either of the following applies:
- 6.11.7.3.1 The rear fog lamp(s) may continue to operate until the position lamps are switched OFF, and the rear fog lamp(s) shall then remain OFF until deliberately switched ON again.

- 6.11.7.3.2 A warning, at least audible, additional to the mandatory tell-tale (6.11.8) shall be given if the ignition is switched OFF or the ignition key is withdrawn and the driver's door is opened, whether the lamps in 6.11.7.1 are ON or OFF whilst the rear fog lamp switch is in the ON position.
- 6.11.7.4 Except as provided in paragraphs 6.11.7.1 and 6.11.7.3, the operation of the rear fog lamp(s) shall not be affected by switching ON or OFF any other lamps.
- 6.11.8 **Tell-tale** : Circuit-closed tell-tale is mandatory. An independent non-flashing warning light.
- 6.11.9 **Other Requirements** : In all cases, the distance between the rear fog lamp and each stop lamp shall be greater than 100 mm.
- 6.12 **Parking Lamp**
- 6.12.1 **Presence** : Optional on motor vehicles not exceeding 6 m in length and not exceeding 2 m in width. On all other vehicles, prohibited.
- 6.12.2 **Number** : According to the arrangement.
- 6.12.3 **Arrangement** : Either two lamps at the front and two lamps at the rear, or one lamp on each side.
- 6.12.4 **Position**
- 6.12.4.1 **Width** : The point on the apparent surface in the direction of the reference axis which is farthest from the vehicle's median longitudinal plane shall not be more than 400 mm from the extreme outer edge of the vehicle. Furthermore, if there are two lamps, they shall be on the sides of the vehicle.
- 6.12.4.2 **Height**
- For M₁ and N₁ category vehicles: no special requirement;
- For all other categories of vehicles: above the ground, not less than 350 mm nor more than 1,500 mm (2,100 mm if the shape of the bodywork makes it impossible to keep within 1,500 mm).
- 6.12.4.3 **Length** : No special requirement.
- 6.12.5 **Geometric Visibility**
- 6.12.5.1 **Horizontal angle** : 45 degrees outwards, forwards and rearwards.
- 6.12.5.2 **Vertical angle** : 15 degrees above and below the horizontal. The vertical angle below the horizontal may be reduced to 5 degrees, however, if the height of the lamp is less than 750mm.
- 6.12.6 **Orientation**: This shall be such that the lamps meet the requirements for visibility forwards and rearwards.

6.12.7 **Electrical Connections**

The connection shall allow the parking lamp(s) on the same side of the vehicle to be lit independently of any other lamps.

The parking lamp(s) and, if applicable, the front and rear position lamps according to paragraph 6.12.9. below, shall be able to operate shall be able to function even if the device which starts the engine is in a position which makes it impossible for the engine to operate. A device which automatically deactivates these lamps as a function of time is prohibited.

6.12.8 **Tell-tale**

Circuit-closed tell-tale is optional. If there is one, it shall not be possible to confuse it with the tell-tale for the front and rear position lamps.

6.12.9 **Other Requirements**

The functioning of this lamp may also be performed by simultaneously switching ON the front and rear position lamps on the same side of the vehicle.

6.13 **End-Outline Marker Lamp**

6.13.1 **Presence:** Mandatory on vehicles and trailers exceeding 2.10 m in width. Optional on vehicles between 1.80 m and 2.10 m in width. On chassis-cabs the rear end outline marker lamps are optional.

6.13.2 **Number :** Two, visible from the front and two, visible from the rear.

6.13.3 **Arrangement :** No special requirement.

6.13.4 **Position**

6.13.4.1 **Width**

Front and rear: As close as possible to the extreme outer edge of the vehicle. This condition is deemed to have been met when the point on the apparent surface in the direction of the reference axis which is farthest from the vehicles median longitudinal plane is not more than 400 mm from the extreme outer edge of the vehicle.

6.13.4.2 **Height**

Front Motor vehicles : The horizontal plane tangential to the upper edge of the apparent surface in the direction of the reference axis of the device shall not be lower than the horizontal plane tangential to the upper edge of the transparent zone of the windscreen.

Trailers and semi-trailers: At the maximum height compatible with the requirements relating to the width, design and operational requirements of the vehicle and to the symmetry of the lamps.

Rear: At the maximum height compatible with the requirements relating to the width, design and operational requirements of the vehicle and to the symmetry of the lamps.

6.13.4.3 **Length :** No special requirement.

6.13.5 **Geometric Visibility**

6.13.5.1 **Horizontal angle :** 80 degrees outwards.

6.13.5.2 **Vertical angle :** 5 degrees above and 20 degrees below the horizontal.

6.13.6 **Orientation:** These shall be such that the lamps meet the requirements for visibility forwards and rearwards.

6.13.7 **Electrical Connections:** Same as paragraph 5.11.

6.13.8 **Tell-tale:** Tell-tale is optional. If it exists, its function shall be carried out by the tell-tale required for the front and rear position lamps.

6.13.9 **Other Requirements:**

Provided that all other requirements are met, the lamp visible from the front and the lamp visible from the rear on the same side of the vehicle may be combined in one device. The position of an end-outline marker lamp in relation to corresponding position lamp shall be such that the distance between the projections on a transverse vertical plane of the points nearest to one another on the apparent surfaces in the direction of the respective reference axes of the two lamps considered is not less than 200 mm.

6.14 **Rear Retro-Reflector (Non-Triangular):**

6.14.1 **Presence :** Mandatory on all motor vehicles of M and N category provided that they may be grouped together with the other rear light-signalling devices. Optional on trailers.

6.14.2 **Number :** Two, the performances of which shall conform to the requirements concerning Class IA or IB retro-reflector as per AIS-057 Additional retro-reflecting devices and materials (including two retro-reflectors not complying with paragraph 6.14.4. below) are permitted provided they do not impair the effectiveness of the mandatory lighting and light-signalling devices.

6.14.3 **Arrangement :** No special requirement.

6.14.4 **Position :**

6.14.4.1 **Width :** The point on the illuminating surface which is farthest from the vehicle's median longitudinal plane shall not be more than 400 mm from the extreme outer edge of the vehicle.

The distance between the inner edges of the two apparent surfaces in the direction of the reference axes shall:

For M₁ and N₁ category vehicles: have no special requirement;

For all other categories of vehicles: not be less than 600 mm apart.

This distance may be reduced to 400 mm where the overall width of the vehicle is less than 1,300 mm.

6.14.4.2 **Height:** Above the ground, not less than 250 mm and not more than 900 mm. If the shape of the bodywork does not permit this, the maximum limit is extended to 1500 mm.

6.14.4.3 **Length:** At the rear of the vehicle.

6.14.5 **Geometric Visibility**

Horizontal angle: 30 degrees inwards and outwards.

Vertical angle: 10degrees above and below the horizontal. The vertical angle below the horizontal may be reduced to 5 degrees in the case of a retro-reflector less than 750 mm above the ground.

6.14.6 **Orientation**

Rearwards.

6.14.7 **Other Requirements**

The illuminating surface of the retro-reflector may have parts in common with the apparent surface of any other lamp situated at the rear.

6.15 **Rear Retro-Reflector (Triangular)**

6.15.1 **Presence :** Mandatory on trailers. Prohibited on all motor vehicles of M and N categories.

6.15.2 **Number :** Two, the performances of which shall conform to the requirements concerning Class III A or III B retro-reflector as per AIS-057. Additional retro-reflecting devices and materials (including two retro-reflectors not complying with paragraph 6.15.4. below), are permitted provided they do not impair the effectiveness of the mandatory lighting and light-signalling devices.

6.15.3 **Arrangement :** The apex of the triangle shall be directed upwards.

6.15.4 **Position**

6.15.4.1 **In width:** that point on the illuminating surface which is farthest from the vehicle's median longitudinal plane shall not be more than 400 mm from the extreme outer edge of the vehicle.

The inner edges of the retro-reflectors shall not be less than 600 mm apart. This distance may be reduced to 400 mm if the overall width of the vehicle is less than 1,300 mm.

6.15.4.2. **In height:** above the ground, not less than 250 mm nor more than 900 mm (1,500 mm if the shape of the bodywork makes it impossible to keep within 900 mm).

6.15.4.3. **In length:** at the rear of the vehicle.

6.15.5. **Geometric visibility**

Horizontal angle: 30 degrees inwards and outwards.

Vertical angle: 15 degrees above and below the horizontal. The vertical angle below the horizontal may be reduced to 5 degrees in the case of a retro-reflector less than 750 mm above the ground.

6.15.6 **Orientation**

Rearwards.

6.15.7 **Other Requirements:**

The illuminating surface of the retro-reflector may have parts in common with the apparent surface of any other lamp situated at the rear.

6.16 **Front Retro-Reflector (Non-Triangular)**6.16.1 **Presence**

Mandatory on trailers and goods vehicles. Mandatory on motor vehicles having all forward facing lamps with reflectors concealable.

- Optional on other motor vehicles.

6.16.2 **Number :** Two, the performances of which shall conform to the requirements concerning Class IA or IB retro-reflectors as per AIS-057 Additional retro-reflecting devices and materials (including two retro-reflectors not complying with paragraph 6.16.4. below), are permitted provided they do not impair the effectiveness of the mandatory lighting and light-signalling devices.

6.16.3 **Arrangement :** No special requirement.

6.16.4 **Position :**

6.16.4.1 **Width :** That point on the illuminating surface which is farthest from the vehicle's median longitudinal plane shall not be more than 400 mm from the extreme outer edge of the vehicle.

In the case of a trailer, the point of the illuminating surface which is farthest from the vehicle's median longitudinal plane shall not be farther than 150 mm from the extreme outer edge of the vehicle.

The distance between the inner edges of the two apparent surfaces in the direction of the reference axes shall:

For M_1 and N_1 category vehicles: have no special requirement;

For all other categories of vehicles: not be less than 600 mm apart. This distance may be reduced to 400 mm if the overall width of the vehicle is less than 1,300 mm.

6.16.4.2 **Height :** Same as paragraph 6.14.4.2.

6.16.4.3 **Length** : At the front of the vehicle.

6.16.5 **Geometric Visibility**

Horizontal angle : 30 degrees inwards and outwards. In the case of trailers, the angle inwards may be reduced to 10 degrees. If because of the construction of the trailers, this angle cannot be met by the mandatory retro-reflectors, then additional (supplementary) retro-reflectors shall be fitted, without the width limitation 6.16.4.1., which shall, in conjunction with the mandatory retro-reflectors, give the necessary visibility angle.

Vertical angle : 10 degrees above and below the horizontal. The vertical angle below the horizontal may be reduced to 5 degrees in the case of a retro-reflector, less than 750 mm above the ground.

6.16.6 **Orientation** : Towards the front.

6.16.7 **Other Requirements** : The illuminating surface of the retro-reflector may have parts in common with the apparent surface of any other lamp situated at the front.

6.17 **Side Retro-Reflector (Non-Triangular)**

6.17.1 **Presence**

Mandatory: On all motor vehicles the length of which exceeds 6 m and on all trailers.

Optional : On motor vehicles, the length of which does not exceeds 6 m.

6.17.2 **Number**: Such that the requirements for longitudinal positioning are complied with. The performances of these devices shall conform to the requirements concerning Class IA or IB retro-reflectors as per AIS-057. Additional retro-reflecting devices and materials (including two retro-reflectors not complying with paragraph 6.17.4. below), are permitted provided they do not impair the effectiveness of the mandatory lighting and light-signalling devices.

6.17.3 **Arrangement**: No special requirement.

6.17.4 **Position**:

6.17.4.1 **Width**: No special requirement.

6.17.4.2 **Height**: Same as paragraph 6.14.4.2.

6.17.4.3 **Length**: At least one side retro-reflector shall be fitted to the middle third of the vehicle, the foremost side retro-reflector being-not further than 3 m from the front; in the case of trailers, account shall be taken of the length of the draw bar for the measurement of this distance. The distance between two adjacent side retro-reflectors shall not exceed 3 m. This does not, however, apply to M₁ and N₁ category vehicles. If the structure of the vehicle does not permit this, this distance may be increased to 4 m. The distance between the rear most side retro-reflector and the rear of the vehicle shall not exceed 1 m. However, for motor vehicles the length of which

does not exceed 6 m, it is sufficient to have one side retro-reflector fitted within the first third and/or one within the last third of the vehicle length.

6.17.5 **Geometric Visibility:**

Horizontal angle : 45 degrees to the front and to the rear.

Vertical angle: 10 degrees above and below the horizontal. The vertical angle below the horizontal may be reduced to 5 degrees in the case of a retro-reflector less than 750 mm above the ground.

6.17.6 **Orientation :** Towards the side.

6.17.7 **Other Requirements:** The illuminating surface of the side retro-reflector may have parts in common with the apparent surface of any other side lamp.

6.18 **Side-Marker Lamps:**

6.18.1 **Presence**

Mandatory: On all vehicles the length of which exceeds 6 m, except for chassis-cabs. The length of trailers shall be calculated including the draw bar.

The SM1 type of side-marker lamp as defined in AIS-012 shall be used on all categories of vehicles. However, the SM2 type of side-marker lamps as defined in AIS-012 may be used on the M₁, category of vehicles.

In addition, on M₁ and N₁ category vehicles less than 6 m in length, side-marker lamps shall be used, if they supplement the reduced geometric visibility requirements of front position lamps conforming to paragraph 6.9.5.2 and rear position lamps conforming to paragraph 6.10.5.2.

Optional: On all other vehicles. The SM1 or SM2 types of side-marker lamps may be used.

6.18.2 **Minimum Number Per Side:** This shall be such that the rules for longitudinal positioning are complied with.

6.18.3 **Arrangement :** No individual specifications.

6.18.4 **Position**

6.18.4.1 **Width :** No individual specifications.

6.18.4.2 **Height :** Above the ground, not less than 250 mm and not more than 1,500 mm. If the shape of the bodywork does not permit this, the maximum limit is extended to 2,100 mm.

6.18.4.3 **Length :** at least one side-marker lamp shall be fitted to the middle third of the vehicle, the foremost side-marker lamp being not further than 3 m from the front; in the case of trailers account shall be taken of the length of the drawbar for the measurement of this distance.

The distance between two adjacent side-marker lamps shall not exceed 3 m. If the structure of the vehicle makes it impossible to comply with such a requirement, this distance may be increased to 4 m.

The distance between the rearmost side-marker lamp and the rear of the vehicle shall not exceed 1 m.

However, for vehicles the length of which does not exceed 6 m and for chassis-cabs, it is sufficient to have one side-marker lamp fitted within the first third and/or within the last third of the vehicle length.

6.18.5 **Geometric Visibility**

Horizontal angle : 45 degrees to the front and to the rear. However for vehicles on which the installation of the side-marker lamps is optional this value can be reduced to 30 degrees.

If the vehicle is equipped with side-marker lamps used to supplement the reduced geometric visibility of front and rear direction indicator lamps conforming to paragraph 6.5.5.2. and/or position lamps conforming to paragraphs 6.9.5.2. and 6.10.5.2., the angles are 45° towards the front and rear ends of the vehicle and 30° towards the centre of the vehicle (see the figure in paragraph 6.5.5.2. above).

Vertical angle: 10 degrees above and below the horizontal. The vertical angle below the horizontal may be reduced to 5 degrees in the case of side marker lamps less than 750 mm above the ground.

6.18.6 **Orientation:** Towards the side.

6.18.7 **Electrical Connections:**

On M₁ and N₁ category vehicles less than 6 m in length amber side-marker lamps may be wired to flash, provided that this flashing is in phase and at the same frequency with the direction indicator lamps at the same side of the vehicle.

For all other categories of vehicles: no individual specification.

6.18.8 **Tell-tale :** Tell-tale is optional. If it exists, its function shall be carried out by the tell-tale required for the front and rear position lamps.

6.18.9 **Other Requirements:**

When the rear most side-marker lamp is combined with the rear position lamp reciprocally incorporated with the rear fog lamp or stop lamp, the photometric characteristics of the side-marker lamp may be, modified during the illumination of the rear fog lamp or stop lamp.

Rear side-marker lamps shall be amber if they flash with the rear direction-indicator lamp.

6.19. Daytime running lamp

6.19.1. Presence

Optional on motor vehicles. Prohibited on trailers.

6.19.2. Number

Two.

6.19.3. Arrangement

No special requirement.

6.19.4. Position

6.19.4.1. In width: that point on the apparent surface in the direction of the reference axis which is farthest from the vehicle's median longitudinal plane shall not be more than 400 mm from the extreme outer edge of the vehicle.

The distance between the inner edges of the apparent surfaces in the direction of the reference axes shall not be less than 600 mm.

This distance may be reduced to 400 mm where the overall width of the vehicle is less than 1,300 mm.

6.19.4.2. In height: above the ground not less than 250 mm nor more than 1,500 mm.

6.19.4.3. In length: at the front of the vehicle. This requirement shall be deemed to be satisfied if the light emitted does not cause discomfort to the driver either directly or indirectly through the rear-view mirrors and/or other reflecting surfaces of the vehicle.

6.19.5. Geometric visibility

Horizontal: outwards 20° and inwards 20°.

Vertical: upwards 10° and downwards 10°.

6.19.6. Orientation

Towards the front.

6.19.7. Electrical connections

If installed, the daytime running lamps shall be switched ON automatically when the device which starts and/or stops the engine is in a position which makes it possible for the engine to operate. It shall be possible to activate and deactivate the automatic switching ON of daytime running lamps without the use of tools. The daytime running lamp shall switch OFF automatically when the headlamps are switched ON, except when the latter are used to give intermittent luminous warnings at short intervals.

- 6.19.8. Tell-tale
 Closed-circuit tell-tale optional.
- 6.19.9. Other prescriptions None.
- 6.20. **Cornering Lamp**
- 6.20.1. Presence
 Optional on motor vehicles.
- 6.20.2. Number
 Two.
- 6.20.3. Arrangement
 No special requirement.
- 6.20.4. Position
- 6.20.4.1. In width: that point on the apparent surface in the direction of the reference axis which is farthest from the vehicle's median longitudinal plane shall not be more than 400 mm from the extreme outer edge of the vehicle.
- 6.20.4.2. In length: not further than 1,000 mm from the front.
- 6.20.4.3. In height:
 minimum: Not less than 250 mm above the ground;
 maximum: Not more than 900 mm above the ground.
- However, no point on the apparent surface in the direction of the reference axis shall be higher than the highest point on the apparent surface in the direction of the reference axis of the dipped-beam headlamp.
- 6.20.5. **Geometric visibility**
 Defined by angles α and β as specified in paragraph 2.13.:
 $\alpha = 10^\circ$ upwards and downwards,
 $\beta = 30^\circ$ to 60° outwards.
- 6.20.6. **Orientation**
 Such that the lamps meet the requirements for geometric visibility.
- 6.20.7. **Electrical connections**
 The cornering lamps shall be so connected that they cannot be activated unless the main-beam headlamps or the dipped-beam headlamps are switched ON at the same time.
- The cornering lamp on one side of the vehicle may only be switched ON automatically when the direction indicators on the same side of the

vehicle are switched ON and/or when the steering angle is changed from the straight-ahead position towards the same side of the vehicle.

The cornering lamp shall be switched OFF automatically when the direction indicator is switched OFF and/or the steering angle has returned in the straight-ahead position.

6.20.8. Tell-tale

None.

6.20.9. Other requirements

The cornering lamps shall not be activated at vehicle speeds above 40 km/h.

7.0 TECHNICAL SPECIFICATIONS TO BE SUBMITTED

7.1 The specifications to be submitted by the manufacturer at the time of applying for the type approval of the vehicle to this standard shall contain at least the information listed in the following paragraphs of AIS-007 (Rev. 3):

A1, A1.1, A1.2, A1.3, A1.4, A1.5, A1.6, A1.7. A3, A3.1, A3.2.1 A6, A6.1, A6.1.1, A6.1.2, A6.1.3, A6.2 A10, A10.1, A10.2, A10.3 A7, A7.2.1, A7.2.2, A7.2.3, A7.3, A7.3.1, A7.3.2, A7.4, A7.4.1, A7.4.2 B10, B10.1, B10.5. E2, E2.1, E2.2, E2.3 E3, E3.1, E3.2, E3.3 E4, E4.1, E4.2, E4.3 E5, E5.1, E5.2, E5.3 E6, E6.1, E6.1.1, E6.1.2, E6.1.3, E6.2, E6.2.1, E6.2.3 E7, E7.1, E7.2, E7.3 E8, E8.1, E8.2, E8.3 E9, E9.1, E9.1.1, E9.1.2, E9.1.3, E9.2, E9.2.1, E9.2.2, E9.2.3, E9.3, E9.3.1, E9.3.2, E9.3.3, E9.3.4. E10, E10.1, E10.1.1, E10.1.2, E10.1.3, E10.2, E10.2.1, E10.2.3, E10.3, E10.3.1, E10.3.2, E10.3.3 E11, E11.1, E11.1.1, E11.1.2, E11.1.3, E11.1.4, E11.2, E11.2.1, E11.2.3, E11.2.4, E11.3, E11.3.1, E11.3.2, E11.3.3, E11.3.4. E12, E12.1, E12.2, E12.3

7.2 In addition, the maximum intensity of main-beam head lamp (cd) and a diagram of the vehicle indicating the location of all lighting and light signalling devices and following dimensions (in mm) shall be submitted.

Note : This paragraph is applicable only till such time the information given in this paragraph is incorporated in AIS-007 (Rev. 3). Once such an amendment to AIS-007(Rev. 3) is implemented, this paragraph will not be an additional requirement.

7.2.1 **Along the Width of the Vehicle** (applicable only in case there are more than one lamp for same function):

7.2.1.1 Horizontal distance between the inner edges of apparent surfaces in the direction of reference axes or illuminating surfaces, as applicable.

7.2.1.2 Distance between outermost edges of the apparent surfaces in the direction of reference axes or illuminating surfaces, as applicable from the extreme outer edge of the vehicle.

- 7.2.1.3 Distance between the nearest points of apparent surfaces in the direction of reference axes of the front direction indicator and the dipped-beam headlamps and category of the front direction indicator 1 or 1a or 1b. and that of rear direction indicator 2a or 2b.
- 7.2.2 **Along Length of the Vehicle Where Applicable:**
- The distance between the edges of the apparent surfaces in the direction of reference axis or illuminating surfaces or light emitting surfaces, as applicable and the transverse plane which marks the forward boundary of the vehicle's overall length.
- 7.2.3 **Height:** Heights of highest and lowest points of apparent surfaces in the direction of reference axes or illuminating surfaces or light-emitting surfaces, as applicable from ground.
- 7.2.4 Contour of the vehicle parts limiting the geometric visibility of the lamps (where applicable).
- 7.2.5 Reference axis of the device.
- 7.2.6 Location of the extreme outer edge of the vehicle.
- 7.2.7 Mark of the illuminating surface, light-emitting surface or apparent surface in the direction of reference axis, as applicable, of the device as declared by the manufacturer.
- 7.2.8 Mark of the median longitudinal plane of the vehicle
- 7.3 If the above information is submitted in a consolidated form of AIS-007 (Rev. 3), for the type approval of the whole vehicle, it is not necessary to submit this information again.
- 7.4 **Changes in the Technical Specifications Already Type Approved:**
- 7.4.1 Every modification pertaining to the information declared in accordance with paragraph 7.1, 7.2 shall be intimated by the manufacturer to the certifying agency.
- 7.4.2 If the changes in parameters are not related to the provisions, no further action need to be taken. If the changes in parameters are related to the provisions, the Testing Agency may then consider whether,
- a) the model with the changed specifications still complies with provisions,
or
 - b) any further verification is required to establish compliance. For considering whether any further verification is required or not, guidelines given in paragraph 8 (Criteria for Extension of Approval) may be used.

7.4.3 In case of 7.4.2(b), verification for only those parameters which are affected by the modifications need to be carried out.

7.4.4 In case of fulfillment of criteria of paragraph 7.4.2 a), or after results of further verification as per paragraph 7.4.2 b) are successful, the approval of compliance shall be extended for the changes carried out.

8.0 CRITERIA FOR EXTENSION OF APPROVAL

8.1 In case of following changes, the verification shall be carried out for establishing compliance of the changed parameters to the requirements specified in this standard.

8.2 Number of any of the mandatory lighting and light signalling devices and any addition to fitment of optional lamps.

8.3 Dimensions prescribed in paragraph 7.2 (or the corresponding paragraphs of AIS-007(Rev. 3) when the amendment to AIS-007(Rev. 3) for incorporating the above becomes effective).

8.4 In case any increase in the dimensions for which a minimum value is specified or any decrease in the dimensions for which a maximum value is specified in this standard, verification on the prototype is not required if the difference between the modified dimension declared by the manufacturer and the requirement specified in this standard is more than 25 mm.

8.5 If there are changes in the contour of the vehicle, which increase the geometric visibility, verification on the prototype is not required.

8.6 While approving fitment of different makes of lighting devices or light-signalling devices, if any of the parameters specified above are affected, verification of compliance to such parameters shall be carried out.

8.7 In case of following changes, the compliance to the paragraph.6.2.6.1.2 of the standard, verification by way of actual testing or by calculations, is required,

8.7.1 Decrease in the wheel base by more than 10 percent

8.7.2 Decrease in the height of head lamp in unladen condition .

8.7.3 Increase in GVW by more than 10 percent

8.7.4 Increase in the ratio of FAW (Front Axle Weight) to RAW (Rear Axle Weight) in unladen condition.

8.8 For changes other than the above, the provisions given in the Preamble of Annex C of AIS-017/2000 (Procedure for Type Approval and Certification of Vehicles for Compliance to Central Motor Vehicles Rules) may be followed.

9.0 CONFORMITY OF PRODUCTION REQUIREMENTS

Whole vehicle COP procedure laid down by the Ministry of Road Transport & Highways shall be applicable. For the purpose of COP, verification of all parameters shall be carried out.

10.0 TRANSITIONAL PROVISIONS

10.1 At the request of the applicant, type approvals for compliance to AIS-008(Rev.1):2010, shall be granted by test agencies from 26th October 2009. Such type approvals shall be deemed to be compliance to AIS-008:2004.

10.2 At the request of applicant, type approval to the compliance to AIS-008:2004 shall be granted up to the notified date of implementation of AIS-008 (Rev.1):2010.

10.3 Type approvals issued for compliance to AIS-008:2004 shall be extended to approval of AIS-008 (Rev.1):2010, subject to satisfactory compliance of the following:

10.3.1 Fitment for headlamp cleaning devices complying to AIS-083 and automatic headlamp leveling devices (if applicable) as per paragraph 6.2.9. of this standard.

10.3.2 Height requirement for front fog lamp as per paragraph 6.3 of this standard.

10.3.3 Mandatory fitment of reversing lamps on T2 , T3 and T4 category of vehicles as per paragraph 6.4.

10.3.4 Widthwise fitment requirements of stop lamps as per clause 6.7 of this standard.

10.3.5 Fitment for stop lamp of category S3 for N1 category vehicles with closed cargo space.

10.3.5 Fitment requirement for daylight running lamps (paragraph 6.19 of this standard) and cornering lamps (paragraph 6.20 of this standard), if fitted.

Note: Additional verification for the above need not be carried out, if compliance to the above requirements has already been established during the type approval as per AIS-008:2004.

10.4 Extension of Approvals for engineering and administrative changes:

10.4.1 In the case of 10.1, extensions shall be granted subject to the conditions of AIS- 008 (Rev.1):2010. Such extensions shall be deemed to be compliance to AIS-008:2004.

10.4.2 In the case of 10.2, extensions shall be granted subject to conditions of AIS-008:2004, till the notified date of implementation of AIS-008(Rev.1):2010

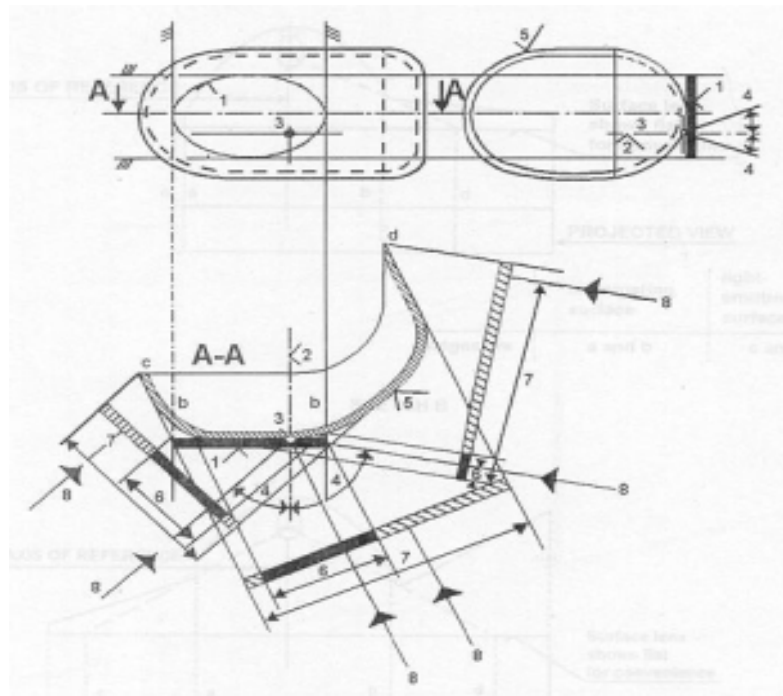

Figure 1

Lamp Surfaces, Axis and Center of Reference and Angles of Geometric Visibility (Ref. paragraphs 2.8, 2.9 and 2.10)

Key

1. Illuminating surface
2. Axis of reference
3. Centre of reference
4. Angle of geometric visibility
5. Light emitting surface
6. Apparent surface based on illuminating surface
7. Apparent surface based light-emitting surface
8. Direction of visibility

Note: Notwithstanding the drawing the apparent surface is to be considered as tangent to the light-emitting surface.

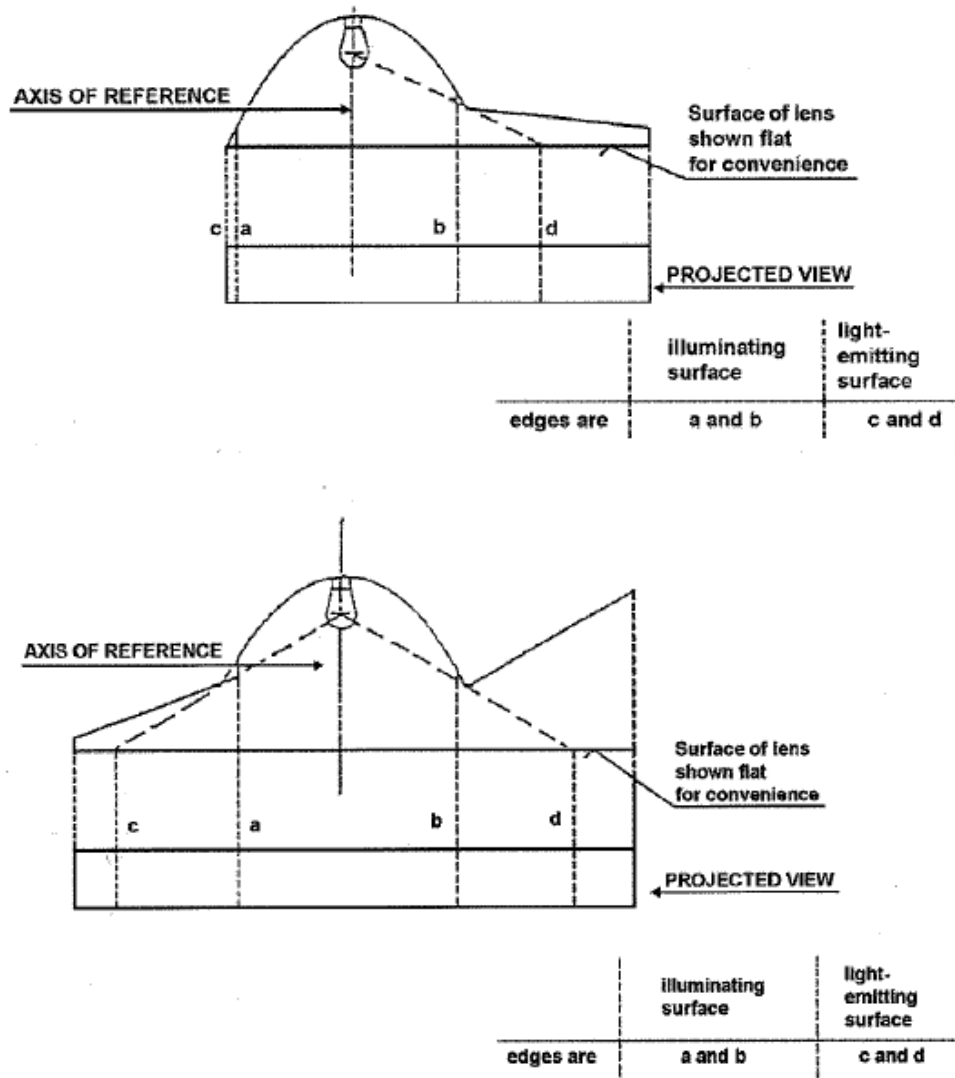

Figure 2

Illuminating Surface in Comparison with – Light – Emitting Surface
 (Ref. paragraphs 2.8, 2.9 and 2.10 of this standard)

Visibility of a Red Lamp to the Front and Visibility of a White Lamp to the Rear (Ref. paragraphs. 5.10.1 and 5.10.2 of this standard)

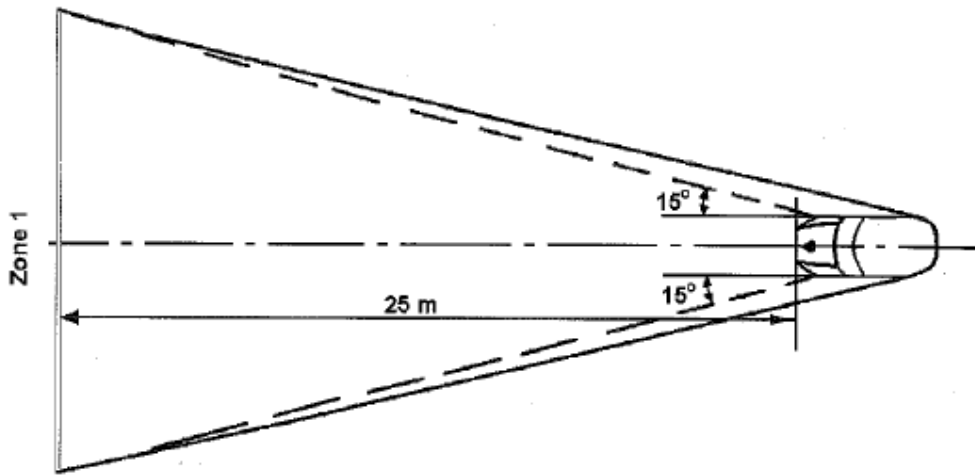

Figure 3
Visibility of a Red Lamp to the Front

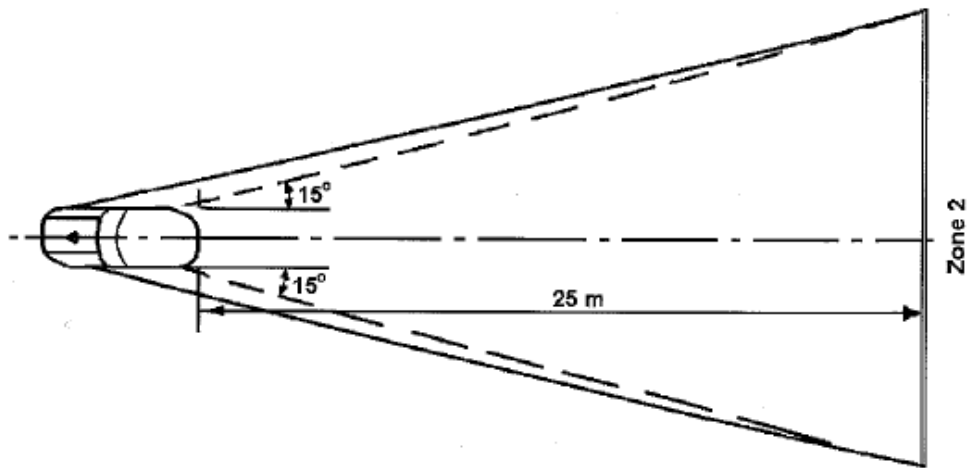
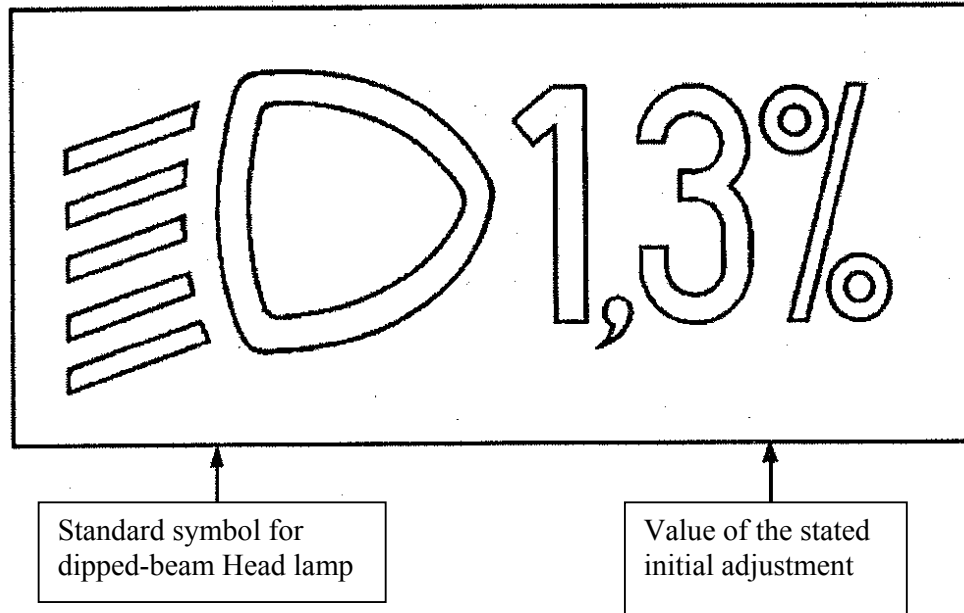

Figure 4
Visibility of a White Lamp to the Rear

ANNEX : A

(See 6.2.6.1.1)

**INDICATION OF THE STATED INITIAL ADJUSTMENT
REFERRED TO IN PARAGRAPH 6.2.6.1.1 OF THIS STANDARD**



The size of the symbol and characters is left to the discretion of the manufacturer.

ANNEX: B

(See 6.2.6.1.2)

**STATES OF LOADING TO BE TAKEN INTO
CONSIDERATION IN DETERMINING VARIATIONS IN
THE VERTICAL ORIENTATION OF THE DIPPED-BEAM
HEADLAMPS**

Loading conditions on axles referred to in paragraphs 6.2.6.1 and 6.2.6.3.1 of this standard.

- 1 For the following tests, the weight of the passengers shall be calculated on the basis of 75 kg per person.
- 2 Loading conditions for different types of vehicles:
 - 2.1 Vehicles in Category M₁:
 - 2.1.1 The angle of the light beam of the dipped-beam headlamps shall be determined under the following load conditions:
 - 2.1.1.1 one person in the driver's seat;
 - 2.1.1.2 the driver, plus one passenger in the front seat farthest from the driver;
 - 2.1.1.3 the driver, one passenger in the front seat farthest from the driver, all the seats farthest to the rear occupied;
 - 2.1.1.4 all the seats occupied;
 - 2.1.1.5 all the seats occupied, plus an evenly distributed load in the luggage boot, in order to obtain the permissible load the rear axle or the front axle if the boot is at the front. If the vehicle has a front and a rear boot, the additional load shall be appropriately distributed in order to obtain the permissible axle loads. However, if the maximum permissible laden weight is obtained before the permissible load on one of the axles, the loading of the boot(s) shall be limited to the figure which enables that weight to be reached;
 - 2.1.1.6 driver, plus an evenly distributed load in the boot, in order to obtain the permissible load on the corresponding axle. However, if the maximum permissible laden weight is obtained before the permissible load on the axle, the loading of the boot(s) shall be limited to the figure which enables that mass to be reached.
 - 2.1.2 In determining the above loading conditions, account shall be taken of any loading restrictions laid down by the manufacturer.
 - 2.2 Vehicles in Categories M₂ and M₃; The angle of the light beam from the dipped-beam headlamps shall be determined under the following loading conditions:
 - 2.2.1 vehicle unladen and one person in the driver's seat;

- 2.2.2 vehicle is laden such that each axle carries its maximum technically permissible load or until the maximum permissible weight of the vehicle is attained by loading the front and rear axles proportionally to their maximum technically permissible load whichever occurs first.
- 2.3 Vehicles in Category N with load surfaces:
 - 2.3.1 The angle of the light beam from the dipped-beam headlamps shall be determined under the following loading conditions;
 - 2.3.1.1 The vehicle unladen and one person in the driver's seat;
 - 2.3.1.2 Driver, plus a load so distributed as to give the maximum technically permissible load on the rear axle or axles, or the maximum permissible weight of the vehicle, whichever occurs first, without exceeding a front axle load calculated as the sum of the front axle load of the unladen vehicle plus 25% of the maximum permissible payload on the front axle. Conversely, the front axle is so considered when the load platform is at the front.
- 2.4 Vehicles in Category N - without a load surface:
 - 2.4.1 Drawing vehicles for semi-trailers:
 - 2.4.1.1 unladen vehicle without a load on the coupling attachment and one person in the driver's seat;
 - 2.4.1.2 one person in the driver's seat: technically permissible load on the coupling attachment in the position of the attachment corresponding to the highest load on the rear axle.
 - 2.4.2 Drawing vehicles for trailers:
 - 2.4.2.1 vehicle unladen and one person in the driver's seat;
 - 2.4.2.2 one person in the driver's seat, all the other places in the driving cabin being occupied.

ANNEX: C

(See 6.2.6.3.2)

**MEASUREMENT OF THE VARIATION OF DIPPED – BEAM
INCLINATION AS A FUNCTION OF LOAD****1. SCOPE**

This annex specifies a method for measuring variations in motor vehicle dipped-beam inclination, in relation to its initial inclination, caused by changes in vehicle attitude due to loading.

2. DEFINITIONS**2.1 Initial Inclination****2.1.1 Stated initial inclination**

The value of the dipped-beam initial inclination specified by the motor vehicle manufacturer serving as a reference value for the calculation of permissible variations.

2.1.2 Measured initial inclination

The mean value of dipped-beam inclination or vehicle inclination measured with the vehicle in condition No.1, as defined in Annex-B, for the category of vehicle under test. It serves as a reference value for the assessment of variations in beam inclination as the load varies.

2.2 Dipped-Beam Inclination

It may be defined as follows :

Either as the angle expressed in milli-radians between the direction of the beam towards a characteristic point on the horizontal part of the cut-off in the luminous distribution of the headlamp and the horizontal plane, or by the tangent of that angle, expressed in percentage inclination, since the angles are small (for these small angles, 1% is equal to 10 mrad). If the inclination is expressed in percentage inclination, it may be calculated by means of the following formula:

$$\frac{(h_1 - h_2)}{L} \times 100$$

Where:

h_1 : is the height above the ground, in mm, of the above mentioned characteristic point, measured on a vertical screen perpendicular to the vehicle longitudinal median plane. placed at a horizontal distance L.

h_2 : is the height above the ground, in mm, of the centre of reference (which is taken to be the nominal origin of the characteristic point chosen in h_1).

L is the distance in mm from the screen to the centre of reference. Negative values denotes downward inclination (see Figure 1). Positive values denote upward inclination.

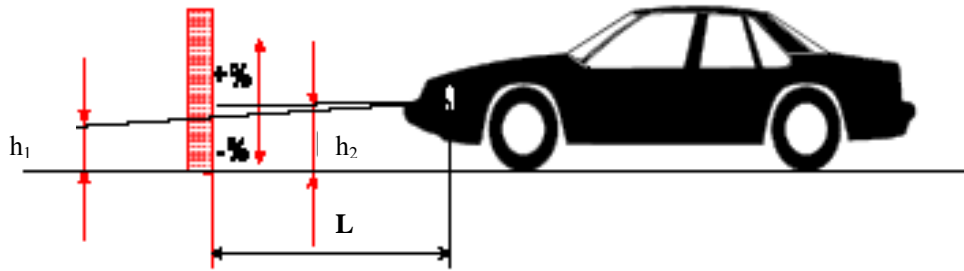

Figure 1
Dipped-beam downward inclination of a category M₁ vehicle

Notes:

1. This drawing represents a Category M₁ vehicle, but the principle shown applies to vehicles of other categories.
2. Where the vehicle does not incorporate a headlamp leveling system, the variation in dipped-beam inclination is identical with the variation in the inclination of the vehicle itself.

3. MEASUREMENT CONDITIONS

- 3.1 If a visual inspection of the dipped-beam pattern on the screen or a photometric method is used, measurement shall be carried out in a dark environment (for example, a dark room) of sufficient area to allow the vehicle and the screen to be placed as shown in Figure 1. Headlamp centres of reference shall be at a distance from the screen of at least 10 m.
- 3.2 The ground on which measurements are made shall be as flat and horizontal as possible, so that the reproducibility of measurements of dipped-beam inclination may be assured with an accuracy of ± 0.5 mrad ($\pm 0.05\%$ inclination).
- 3.3 If a screen is used, its marking, position and orientation in relation to the median longitudinal plane of the vehicle shall be such that the reproducibility of the measurement of the dipped-beam inclination may be assured with an accuracy of ± 0.5 mrad ($\pm 0.05\%$ inclination).
- 3.4 During the measurements the ambient temperature shall be between 10 and 40 °C.

4. VEHICLE PREPARATION

- 4.1 Measurements shall be carried out on a vehicles which has travelled a distance specified by the manufacturer.
- 4.2 Tyres shall be inflated to the full-load pressure specified by the vehicle manufacturer. The vehicle shall be fully replenished (fuel, water, oil) and equipped with all the accessories and, tools specified by the manufacturer.

Full fuel replenishment means that the fuel tank shall be filled to not less than 90% of its capacity.

- 4.3 The vehicle shall have the parking brake released and the gear box in neutral.
- 4.4 The vehicle shall be conditioned for at least 8 hrs. at a temperature specified in paragraph 3.4 above in this annex.
- 4.5 If a photometric or visual method is used, headlamps with well defined dipped-beam cut-off should preferably be installed on the vehicle under test in order to facilitate the measurements. Other means are allowed to obtain a more precise reading (for example, removal of the headlamp lens).

5. TEST PROCEDURE

5.1 General

The variations in either dipped-beam or vehicle inclination, depending on the method chosen, shall be measured separately for each side of the vehicle. The results obtained from both left and right headlamps under all the load conditions specified in Annex.B shall be within the limits set out in paragraph 5.5 below. The load shall be applied gradually without subjecting the vehicle to excessive shocks.

5.2 Determination of the Measured Initial Inclination

The vehicle shall be prepared as specified in paragraph 4 above in this annex and laden as specified in Annex B (first loading condition of the respective vehicle category).

Before each measurement, the vehicle shall be rocked as specified in paragraph 5.4 below.

Measurements shall be made three times.

- 5.2.1 If none of the three measured results differ by more than 2 mrad (0.2% inclination) from the arithmetic mean of the results, that mean shall constitute the final result.
- 5.2.2 If any measurement differs from the arithmetic mean of the results by more than 2 mrad (0.2% inclination), a further series of 10 measurements shall be made, the arithmetic mean of which shall constitute the final result.

5.3 Measurement Methods

Any method may be used to measure variations of inclination provided that the readings are accurate to be within ± 0.2 mrad ($\pm 0.02\%$ inclination).

5.4 Treatment of Vehicle in each Loading Condition

The vehicle suspension and any other part likely to affect dipped-beam inclination shall be activated according to the methods described below. However, the test agencies and manufacturers may jointly propose other methods (either experimental or based upon calculations), especially when the test poses particular problems, provided such calculations are clearly valid.

5.4.1 M_1 category vehicles with conventional suspension

With the vehicle standing on the measuring site and, if necessary with the wheels resting on floating platforms (which shall be used if their absence would lead to restriction of the suspension movement likely to affect the results of measurements), rock the vehicle continuously for at least three complete cycles, for each cycle, first the rear and then the front end of the vehicle is pushed down. Rocking sequence shall end with the completion of a cycle. Before making the measurements, the vehicle shall be allowed to come to rest spontaneously instead of using floating platforms, the same effect can be achieved by moving the vehicle backwards and forwards for at least a complete wheel revolution.

5.4.2 M_2 , M_3 and N category vehicles with conventional suspension

5.4.2.1 If the treatment method for Category M_1 vehicles described in paragraph 5.4.1 is not possible, the method described in paragraph 5.4.2.2 or 5.4.2.3 may be used.

5.4.2.2 With the vehicle standing on the measuring site and the wheels on the ground, rock the vehicle by temporarily varying the load.

5.4.2.3 With the vehicle standing on the measuring site and the wheels on the ground, activate the vehicle suspension and all other parts which may affect the dipped-beam inclination by using a vibration rig. This can be a vibrating platform on which the wheels rest.

5.4.3 Vehicles with non-conventional suspension, where the engine has to be running: Before making any measurements wait until the vehicle has assumed its final attitude with the engine running.

5.5 **Measurements**

The variation of the inclination of the dipped-beam shall be assessed for each of the different loading conditions in relation to the measured initial inclination determined in accordance with paragraph 5.2 above.

If the vehicle is fitted with a manual headlamp-leveling system, the latter shall be adjusted to the positions specified by the manufacturer for given loading conditions (according to Annex).

5.5.1 To begin with, a single measurement shall be made in each loading condition. Requirements have been met if, for all the loading condition, the variation in inclination is within the calculated limits (for example, within the difference between the stated initial inclination and the lower and upper limits specified for approval) with a safety margin of 4 mrad (0.4% inclination).

5.5.2 If the result(s) of any measurement(s) does (do) not lie within the safety margin indicated in paragraph 5.5.1 or exceed(s) the limit values, a further three measurements shall be made in the loading conditions corresponding to this (these) result(s) as specified in paragraph 5.5.3.

- 5.5.3 For each of the above loading conditions:
- 5.5.3.1 If none of the three measured results differs by more than 2 mrad (0.2% inclination) from the arithmetic mean of the results, that mean shall constitute the final result.
 - 5.5.3.2 If any measurement differs from the arithmetic mean of the results by more than 2 mrad (0.2% inclination), a further series of 10 measurements shall be made, the arithmetic mean of which shall constitute the final result
 - 5.5.3.3 If a vehicle is fitted with an automatic headlamp leveling system which has an inherent hysteresis loop, average results at the top and bottom of the hysteresis loop shall be taken as significant values.

All these measurements shall be made in accordance paragraph 5.5.3.1 and paragraph 5.5.3.2.
- 5.5.4 Requirements have been met, if, under all loading conditions, the variation between the measured initial inclinations determined in accordance with paragraph 5.2. and the inclination measured under each loading condition is less than the values calculated in paragraph 5.5.1 of this annex. (without safety margin).
- 5.5.5 If only one of the calculated upper or lower limits of variation is exceeded, the manufacturer shall be permitted to choose a different value for the stated initial inclination, within the limits specified for approval.

ANNEX: D

(See 6.2.6.2.2)

THE CONTROLS FOR THE HEAD LAMP - LEVELING DEVICES**1.0 Specifications**

Downward inclination of the dipped-beam shall in all cases be produced in one of the following ways:

- 1.1 by moving a control downwards or to the left,
- 1.2 by rotating a control in a counter clockwise direction,
- 1.3 by depressing a button (push - pull control).
- 1.4 If several buttons are used to adjust the beam, the button which gives the greatest downward to the left or below the buttons of other dipped-beam positions.
- 1.5 A rotary control which is installed edge - on, or with the edge visible, shall follow the operating principles of controls of types 1.1 or 1.3.
- 2.0 This control shall carry symbols indicating clearly the movements corresponding to the downward and upward inclination of dipped-beam.
- 3.0 The "O" position corresponds to initial inclination according to paragraph 6.2.6.1.1 of the standard.
- 4.0 The "O" position which, according to paragraph 6.2.6.2.2. of this standard has to be a " stop position ", need not necessarily be at the end of the scale.
- 5.0 The marks used on the controls shall be explained in the owners handbook.
- 6.0 Only the following symbols may be used to identify the controls.

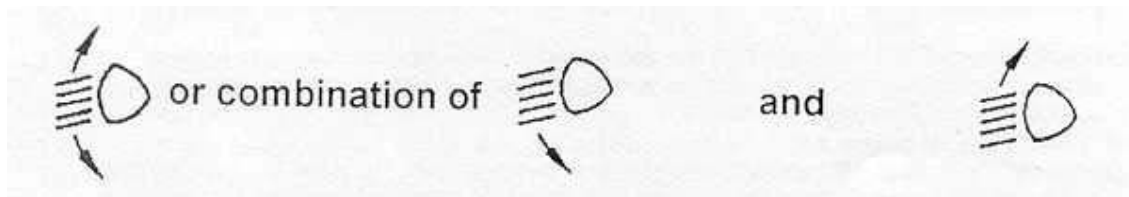

Symbols employing four lines instead of five may also be used

Example 1:

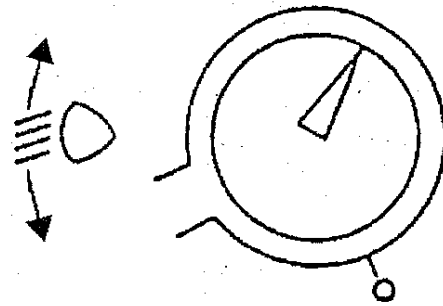

Example 2:

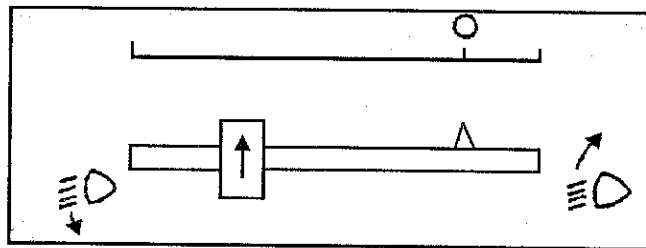

Example 3:

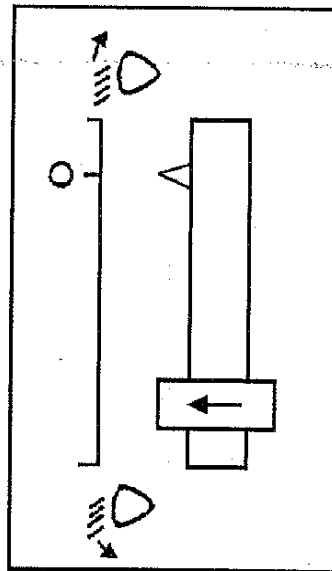

ANNEX: E

(See 2.7.1)

EXAMPLES OF LIGHT SOURCE OPTIONS

"Standard"

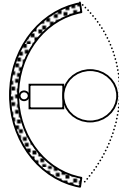

Light Source:
Replaceable
Approved to standard

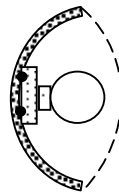

LIGHT SOURCE MODULE
Light Source:
Non-replaceable
Non-approved

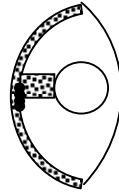

SEALED
Light Source:
Non-replaceable
Non-approved

DLS

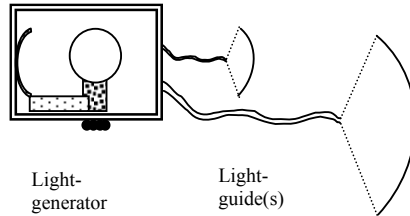
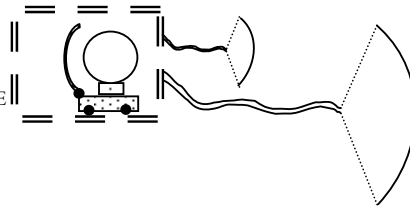
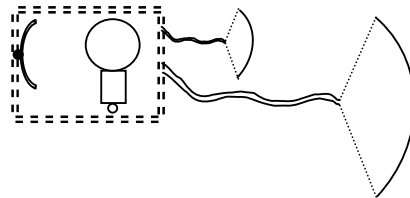

Light-
generator

Light-
guide(s)

Outer
lens(es)

ANNEX F
(See Introduction)

COMPOSITION OF AISC PANEL*

Convener	
Mr. R. M. Kanitkar	Society of Indian Automobile Manufacturers (SIAM) (Force Motors Ltd.)
Members	Representing
Mr. A. S. Bhale / Mr. B. V. Shamsundara	The Automotive Research Association of India (ARAI)
Mr. D. P. Saste / Mr. V. D. Chavan	Central Institute of Road Transport (CIRT)
Dr. Madhusudan Joshi	International Centre for Automotive Technology (ICAT)
Mr. G.R.M. Rao	Vehicles Research & Development Establishment (VRDE)
Mr. T. V. Singh	Bureau of Indian Standards (BIS), New Delhi
Dr. N. Karuppaiah	National Automotive Testing and R&D Infrastructure Project (NATRIP)
Mr. K. K. Gandhi	Society of Indian Automobile Manufacturers (SIAM)
Mr. T. M. Balaraman	Society of Indian Automobile Manufacturers (SIAM) (Bajaj Auto Ltd.)
Mr. Z. A. Mujawar	Society of Indian Automobile Manufacturers (SIAM) (Mahindra and Mahindra Ltd.)
Mr. S. Sakthivelan	Society of Indian Automobile Manufacturers (SIAM) (Toyota Kirloskar Motor Pvt. Ltd.)
Mr. Prakash Vemali	Society of Indian Automobile Manufacturers (SIAM) (Mercedes Benz India Ltd.)
Mr. Jitendra Malhotra	Society of Indian Automobile Manufacturers (SIAM) (Maruti Suzuki India Ltd.)
Mr. Harjeet Singh/ Mr. Harsh Agrawal	Society of Indian Automobile Manufacturers (SIAM) (Hero Honda Motors Ltd.)
Mr. S Ramiah	Society of Indian Automobile Manufacturers (SIAM) (TVS Motor Company Limited)
Mr. Sumit Sharma	Society of Indian Automobile Manufacturers (SIAM) Volkswagen India Private Ltd.
Mr. T.C. Gopalan	Tractor Manufacturers Association (TMA)
Mr. K. N. D. Nambudiripad	Automotive Components Manufacturers Association of India (ACMA)
Mr. G. V. George	Automotive Components Manufacturers Association of India (ACMA) (FIEM Industries Ltd.)

AIS-008 (Revision-1)

Mr. Virendra K. Sachdev/ Mr. Rajesh Bhatt	Automotive Components Manufacturers Association of India (ACMA) (Lumax Industries Ltd.).
Mr. Sagar Kulkarni	Automotive Components Manufacturers Association of India (ACMA) (Rinder India Pvt. Ltd)
Mr. Rajiv Agarwal / Mr. C. K. Choudhari,	All India Auto & Miniature Bulb and Component Mfr. Association

* At the time of approval of this Automotive Industry Standard (AIS)

ANNEX: G

(See Introduction)

COMMITTEE COMPOSITION ***Automotive Industry Standards Committee**

Chairman	
Shri Shrikant R. Marathe	Director The Automotive Research Association of India, Pune
Members	Representing
Representative from	Ministry of Road Transport & Highways (Dept. of Road Transport & Highways), New Delhi
Representative from	Ministry of Heavy Industries & Public Enterprises (Department of Heavy Industry), New Delhi
Shri S. M. Ahuja	Office of the Development Commissioner, MSME, Ministry of Micro, Small & Medium Enterprises, New Delhi
Shri T. V. Singh	Bureau of Indian Standards, New Delhi
Director Shri D. P. Saste (Alternate)	Central Institute of Road Transport, Pune
Dr. M. O. Garg	Indian Institute of Petroleum, Dehra Dun
Dr. C. L. Dhamejani	Vehicles Research & Development Establishment, Ahmednagar
Representatives from	Society of Indian Automobile Manufacturers
Shri T.C. Gopalan	Tractor Manufacturers Association, New Delhi
Shri K.N.D. Nambudiripad	Automotive Components Manufacturers Association of India, New Delhi
Shri Arvind Gupta	Automotive Components Manufacturers Association of India, New Delhi

Member Secretary
Mrs. Rashmi Urdhwareshe
Deputy Director
The Automotive Research Association of India, Pune

* At the time of approval of this Automotive Industry Standard (AIS)