

AUTOMOTIVE INDUSTRY STANDARD

**Automotive Vehicles –Requirements
for Electromagnetic Compatibility**

PRINTED BY
THE AUTOMOTIVE RESEARCH ASSOCIATION OF INDIA
P.B. NO. 832, PUNE 411 004
ON BEHALF OF
AUTOMOTIVE INDUSTRY STANDARDS COMMITTEE
UNDER
CENTRAL MOTOR VEHICLE RULES – TECHNICAL STANDING COMMITTEE
SET-UP BY
MINISTRY OF SHIPPING, ROAD TRANSPORT & HIGHWAYS
(DEPARTMENT OF ROAD TRANSPORT & HIGHWAYS)
GOVERNMENT OF INDIA

July 2009

Status chart of the standard to be used by the purchaser for updating the record

Sr. No.	Corrigenda	Amendment	Revision	Date	Remark	Misc.

INTRODUCTION

The Government of India felt the need for a permanent agency to expedite the publication of standards and development of test facilities in parallel when the work on the preparation of the standards is going on, as the development of improved safety critical parts can be undertaken only after the publication of the standard and commissioning of test facilities. To this end, the erstwhile Ministry of Surface Transport (MOST) has constituted a permanent Automotive Industry Standards Committee (AISC) vide order No.RT-11028/11/97-MVL dated September 15, 1997. The standards prepared by AISC will be approved by the permanent CMVR Technical Standing Committee (CTSC). After approval, the Automotive Research Association of India, (ARAI), Pune, being the Secretariat of the AIS Committee, has published this standard. For better dissemination of this information ARAI may publish this document on their web site.

To ensure that the electromagnetic radiations emitted by vehicle and by its various electronic sub-systems do not cause any undue interference with external systems, a standard on the permissible limits of such radiations, AIS-004 (Part 1) already exists and is in force under CMVR w.e.f. 1st July 2003. With the advancement of automotive technology electronic content in automotive vehicles, especially in engine control, braking control is increasing. Hence a need is felt to formulate requirements of immunity of vehicles and their electronic sub-systems to external electromagnetic radiations from e.g. Radio / TV / Mobile Transmitters. Accordingly immunity test standard AIS-004 (Part 2) “Electromagnetic Radiated Immunity of Automotive Vehicles – Requirements and Methods of Tests” is prepared by the panel constituted by AISC. While preparing this AIS considerable assistance was derived from following ECE Regulation No. 10 (Rev.2, Amd 2) (Supp.2 to 02 series of Amendment, Date of entry into force Aug. 12, 2004) (Issue: 3 Oct/2004) : Uniform provisions concerning the Approval of Vehicles with regard to Electromagnetic Compatibility. However this regulation is undergoing revision to Rev.3 in European Union. Hence the same AISC panel has been entrusted with the task of formulating new consolidated standard for the requirements of radiated emissions and immunity for automotive vehicles in line with ECE R 10 Rev.3. This standard AIS-004 (Part 3) is prepared in line with ECE R 10 Rev. 3.

The Automotive Industry Standards Committee responsible for preparation of this standard is given in Annex 10.

Automotive Vehicles - Requirements for Electromagnetic Compatibility

Clause/ Annex No.	Contents	Page No.
1.	Scope	1/60
2.	Definitions	1/60
3.	Application for approval	3/60
4.	Approval	6/60
5.	Specifications	7/60
6.	Amendment or extension of a vehicle type approval following ESA addition or substitution	12/60
7.	Conformity of production	13/60
8.	Modification and extension of type approval of a vehicle or ESA	14/60
ANNEXES		
Annex 1A	Technical specifications for type approval of a vehicle, with respect to electromagnetic compatibility.	22/60
Annex 1B	Technical specifications for type approval of an electric/electronic sub-assembly, with respect to electromagnetic compatibility	27/60
Annex 2	Method of measurement of radiated broadband electromagnetic emissions from vehicles	28/60
Annex 3	Method of measurement of radiated narrowband electromagnetic emissions from vehicles	32/60
Annex 4	Method of testing for immunity of vehicles to electromagnetic radiation	34/60
Annex 5	Method of measurement of radiated broadband electromagnetic emissions from electrical/electronic sub assemblies	42/60
Annex 6	Method of measurement of radiated narrowband electromagnetic emissions from electrical/electronic sub assemblies	45/60
Annex 7	Method(s) of testing for immunity of electrical/electronic sub-assemblies to electromagnetic radiation	47/60
Annex 8	Method(s) of testing for immunity to and emission of transients of electrical/electronic sub-assemblies	54/60
Annex 9A	Guidelines for deciding applicability, worst case criteria (WCC) and criteria for extension of approval (CEA) for radiated immunity test	55/60
Annex 9B	Guidelines for deciding applicability, worst case criteria (WCC) and criteria for extension of approval (CEA) for radiated emission test	58/60

Automotive Vehicles – Requirements for Electromagnetic Compatibility

1.0 SCOPE

This standard applies to:

- 1.1 vehicles of categories L, M, N and T (Refer AIS-053 for vehicle category definitions) with regard to electromagnetic compatibility;
- 1.2 Components and separate technical units intended to be fitted in these vehicles with the limitation given in paragraph 3.2.1 with regard to electromagnetic compatibility.

It covers:

- (a) requirements regarding the immunity to radiated and conducted disturbances for functions related to direct control of the vehicle, related to driver, passenger and other road users' protection and related to disturbances, which would cause confusion to the driver or other road users;
- (b) requirements regarding the control of unwanted radiated and conducted emissions to protect the intended use of electrical or electronic equipment at own or adjacent vehicles or nearby, and the control of disturbances from accessories that may be retrofitted to the vehicle.

2.0 DEFINITIONS

For the purposes of this standard:

- 2.1 "**Electromagnetic compatibility**" means the ability of a vehicle or component(s) or separate technical unit(s) to function satisfactorily in its electromagnetic environment without introducing intolerable electromagnetic disturbances to anything in that environment.
- 2.2 "**Electromagnetic disturbance**" means any electromagnetic phenomenon which may degrade the performance of a vehicle or component(s) or separate technical unit(s), or of any other device, unit of equipment or system operated in vicinity of a vehicle. An electromagnetic disturbance may be electromagnetic noise, an unwanted signal or a change in the propagation medium itself.
- 2.3 "**Electromagnetic immunity**" means the ability of a vehicle or component(s) or separate technical unit(s) to operate without degradation of performance in the presence of (specified) electromagnetic disturbances which includes wanted radio frequency signals from radio transmitters or radiated in-band emissions of industrial-scientific-medical (ISM) apparatus, internal or external to the vehicle.
- 2.4 "**Electromagnetic environment**" means the totality of electromagnetic phenomena existing at a given location.

- 2.5 **"Broadband emission"** means an emission, which has a bandwidth greater than that of a particular measuring apparatus or receiver (International Special Committee on Radio Interference (CISPR) 25, second edition).
- 2.6 **"Narrowband emission"** means an emission which has a bandwidth less than that of a particular measuring apparatus or receiver (CISPR 25, second edition).
- 2.7 **"Electrical/electronic system"** means an electrical and or electronic device or set of devices together with any associated electrical connections which forms part of a vehicle but which is not intended to be type approved separately from the vehicle.
- 2.8 **"Electrical/electronic sub-assembly"** (ESA) means an electrical and/or electronic device or set(s) of devices intended to be part of a vehicle, together with any associated electrical connections and wiring, which performs one or more specialised functions. An ESA may be approved at the request of a manufacturer or his authorized representative as either a "component" or a "separate technical unit (STU)".
- 2.9 **"Vehicle type"** in relation to electromagnetic compatibility, means vehicles which do not differ essentially in such respects as:
- 2.9.1 The overall size and shape of the engine compartment;
- 2.9.2 The general arrangement of the electrical and/or electronic components and the general wiring arrangement;
- 2.9.3 The primary material of which the body or shell of the vehicle is constructed (for example, a steel, aluminum or fiberglass body shell). The presence of panels of different material does not change the vehicle type provided the primary material of the body is unchanged. However, such variations must be notified.
- 2.10 An **"ESA type"** in relation to electromagnetic compatibility means ESAs, which do not differ in such essential respects as:
- 2.10.1 The function performed by the ESA;
- 2.10.2 The general arrangement of the electrical and/or electronic components, if applicable.
- 2.11 **"Vehicle wiring harness"** means supply voltage, bus system (e.g. CAN), signal or active antenna cables, which are installed by the vehicle manufacturer.
- 2.12 **"Immunity related functions"** are:
- (a) Functions related to the direct control of the vehicle:
- (i) by degradation or change in: e.g. engine, gear, brake, suspension, active steering, speed limitation devices;
- (ii) by affecting drivers position: e.g. seat or steering wheel positioning;
- (iii) by affecting driver's visibility: e.g. dipped beam, windscreen wiper.
- (b) Functions related to driver, passenger and other road user protection:
- (i) e.g. airbag and safety restraint systems.

- (c) Functions which when disturbed cause confusion to the driver or other road users:
 - (i) optical disturbances: incorrect operation of e.g. direction indicators, stop lamps, end outline marker lamps, rear position lamp, light bars for emergency system, wrong information from warning indicators, lamps or displays related to functions in subparagraphs (a) or (b) which might be observed in the direct view of the driver;
 - (ii) acoustical disturbances: incorrect operation of e.g. anti-theft alarm, horn.
- (d) Functions related to vehicle data bus functionality:
 - (i) by blocking data transmission on vehicle data bus-systems, which are used to transmit data, required to ensure the correct functioning of other immunity related functions.
- (e) Functions which when disturbed affect vehicle statutory data: e.g. tachograph, odometer.

3.0 APPLICATION FOR APPROVAL

3.1 Approval of a Vehicle Type

- 3.1.1 The application for approval of a vehicle type, with regard to its electromagnetic compatibility, shall be submitted by the vehicle manufacturer.
- 3.1.2 The technical specifications to be submitted at the time of applying for type approval are as given in Annex 1A.
- 3.1.3 The vehicle manufacturer shall draw up a schedule describing all relevant vehicle electrical/electronic systems or ESAs, body styles, variations in body material, general wiring arrangements, engine variations, and wheelbase versions. Relevant vehicle electrical/electronic systems or ESAs are those which may emit significant broadband or narrowband radiation and/or those which are involved in immunity related functions of the vehicle (see paragraph 2.12.)
- 3.1.4. A representative vehicle of the type to be approved shall be selected from this schedule by mutual agreement between the manufacturer and the Test Agency. The choice of vehicle shall be based on the electrical/electronic systems offered by the manufacturer. One or more vehicles may be selected from this schedule if it is considered by mutual agreement between the manufacturer and the Test Agency that different electrical/electronic systems are included which are likely to have a significant effect on the vehicle's electromagnetic compatibility compared with the first representative vehicle.

While deciding combinations of different makes, elements having radio interference control equipment (resistive elements, shielded cap etc.) as specified by vehicle manufacturer shall only be considered for radiated emission testing. Different makes of elements not contributing to radio interference control (non-resistive HT coil, Non-resistive HT cable, magneto, CDI, non-resistive spark plug, non-resistive spark plug cap etc.) shall not be considered in the combinations to be tested.

- 3.1.5. The choice of the vehicle(s) in conformity with paragraph 3.1.4 above shall be limited to vehicle/electrical/electronic system combinations intended for actual production.

- 3.1.6 The manufacturer may supplement the application with a report on tests which have been carried out. Any such data provided may be used by the Test Agency for the purpose of issuing type-approval.
- 3.1.7 If the Test Agency responsible for the type approval test carries out the test itself, then a vehicle representative of the type to be approved according to paragraph 3.1.4. shall be provided.
- 3.1.8 For vehicles of categories M, N, and T the vehicle manufacturer must provide a statement of frequency bands, power levels, antenna positions and installation provisions for the installation of radio frequency transmitters (RF-transmitters), even if the vehicle is not equipped with an RF transmitter at the time of type approval. This should cover all mobile radio services normally used in vehicles. This information must be made publicly available following the type approval.

Vehicle manufacturers must provide evidence that vehicle performance is not adversely affected by such transmitter installations.

- Note: 1) The above need be declared only for recommended fitments of RF transmitters.
 2) These requirements are deemed to have met if vehicle manufacturer specifies that there is no provision of fitting RF transmitters on the vehicle.

3.2 **ESA Type Approval**

3.2.1 Applicability of this standard to ESA:

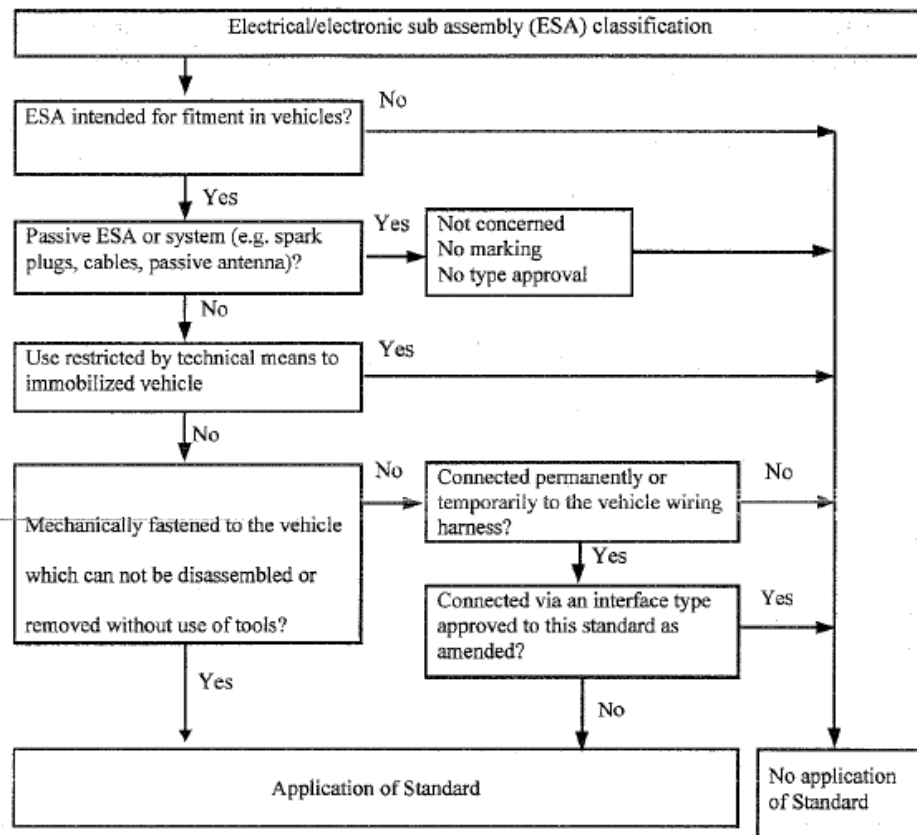

- 3.2.2 The application for approval of a type of ESA with regard to its electromagnetic compatibility shall be submitted by the vehicle manufacturer or by the manufacturer of the ESA.
- 3.2.3 The technical specifications to be submitted at the time of applying for type approval are as given in Annex 1B.
- 3.2.4 The manufacturer may supplement the application with a report on tests which have been carried out. Any such data provided may be used by the Test Agency for the purpose of issuing type-approval.
- 3.2.5 If the Test Agency responsible for the type approval test carries out the test itself, then a sample of the ESA system representative of the type to be approved shall be provided, if necessary, after discussion with the manufacturer on, e.g., possible variations in the layout, number of components, number of sensors. If the Test Agency deems it necessary, it may select a further sample.
- 3.2.6 The sample(s) must be clearly and indelibly marked with the manufacturer's trade name or mark and the type designation.
- 3.2.7 Where applicable, any restrictions on use should be identified. Any such restrictions should be included in Annex 1B.
- 3.2.8 ESA which are brought to the market as spare parts need no type approval if they are obviously marked as a spare part by an identification number and if they are identical and from the same manufacturer as the corresponding original equipment manufacturer (OEM) part for an already type approved vehicle.
- 3.2.9 Components sold as aftermarket equipment and intended for the installation in motor vehicles need no type approval if they are not related to immunity related functions (see paragraph 2.12). In this case a declaration must be issued by the manufacturer that the ESA fulfils the requirements of this standard and in particular the limits defined in paragraphs 5.5, 5.6, 5.8 and 5.9.

4.0 APPROVAL

4.1 Type Approval Procedures

4.1.1 Type Approval of a Vehicle

The following alternative procedures for vehicle type approval may be used at the discretion of the vehicle manufacturer.

4.1.1.1 Approval of a Vehicle Installation

A vehicle installation may be type approved directly by following the provisions laid down in paragraph 5 of this standard. If this procedure is chosen by a vehicle manufacturer, no separate testing of electrical/electronic systems or ESAs is required.

4.1.1.2 Approval of Vehicle Type by Testing of Individual ESAs

A vehicle manufacturer may obtain approval for the vehicle by demonstrating to the Test Agency that all the relevant (See paragraph 3.1.3. of this standard) electrical/electronic systems or ESAs have been approved in accordance with this standard and have been installed in accordance with any conditions attached thereto.

4.1.1.3 A manufacturer may obtain approval according to this standard if the vehicle has no equipment of the type, which is subject to immunity or emission tests. Such approvals do not require testing.

4.1.2 Type Approval of an ESA

Type approval may be granted to an ESA to be fitted either to any vehicle type (component approval) or to a specific vehicle type or types requested by the ESA manufacturer (separate technical unit approval).

4.1.3 ESAs, which are intentional RF transmitters, which have not received type approval in conjunction with a vehicle manufacturer, must be supplied with suitable installation guidelines

4.2 Granting of Type Approval

4.2.1 Vehicle

4.2.1.1 If the representative vehicle fulfils the requirements of paragraph 5 of this standard, type approval shall be granted.

4.2.2 ESA

4.2.2.1 If the representative ESA system(s) fulfil(s) the requirements of paragraph 5 of this standard, type approval shall be granted.

5.0 SPECIFICATIONS

5.1 General Specifications

5.1.1 A vehicle and its electrical/electronic system(s) or ESA(s) shall be so designed, constructed and fitted as to enable the vehicle, in normal conditions of use, to comply with the requirements of this standard.

5.1.1.1 A vehicle shall be tested for radiated emissions and for immunity to radiated disturbances. No tests for conducted emissions or immunity to conducted disturbances are required for vehicle type approval.

5.1.1.2 ESA(s) shall be tested for radiated and conducted emissions, for immunity to radiated and conducted disturbances.

5.1.2 Before testing the Test Agency has to prepare a test plan in conjunction with the manufacturer, which contains at least mode of operation, stimulated function(s), monitored function(s), pass/fail criterion (criteria) and intended emissions.

5.2 Specifications Concerning Broadband Electromagnetic Radiation from Vehicles

5.2.1 Method of Measurement

The electromagnetic radiation generated by the vehicle representative of its type shall be measured using the method described in Annex 2. The method of measurement shall be defined by the vehicle manufacturer in accordance with the Test Agency.

5.2.2 Vehicle broadband type approval limits

5.2.2.1 If measurements are made using the method described in Annex 2 using a vehicle-to-antenna spacing of 10.0 ± 0.2 m, the limits shall be 32 dB microvolts/m in the 30 to 75 MHz frequency band and 32 to 43 dB microvolts/m in the 75 to 400 MHz frequency band, this limit increasing logarithmically with frequencies above 75 MHz as shown in Appendix 2. In the 400 to 1,000 MHz frequency band the limit remains constant at 43 dB microvolts/m

5.2.2.2 If measurements are made using the method described in Annex 2 using a vehicle-to-antenna spacing of 3.0 ± 0.05 m, the limits shall be 42 dB microvolts/m in the 30 to 75 MHz frequency band and 42 to 53 dB microvolts/m in the 75 to 400 MHz frequency band, this limit increasing logarithmically with frequencies above 75 MHz as shown in Appendix 3. In the 400 to 1,000 MHz frequency band the limit remains constant at 53 dB microvolts/m.

5.2.2.3 On the vehicle representative of its type, the measured values, expressed in dB microvolts/m shall be below the type approval limits

- 5.3 **Specifications Concerning Narrowband Electromagnetic Radiation from Vehicles**
- 5.3.1 Method of Measurement
- The electromagnetic radiation generated by the vehicle representative of its type shall be measured using the method described in Annex 3. These shall be defined by the vehicle manufacturer in accordance with the Test Agency.
- 5.3.2 Vehicle narrowband type approval limits
- 5.3.2.1 If measurements are made using the method described in Annex 3 using a vehicle-to-antenna spacing of 10.0 ± 0.2 m, the limits shall be 22 dB microvolts/m in the 30 to 75 MHz frequency band and 22 to 33 dB microvolts/m in the 75 to 400 MHz frequency band, this limit increasing logarithmically with frequencies above 75 MHz as shown in Appendix 4. In the 400 to 1,000 MHz frequency band the limit remains constant at 33 dB microvolts/m.
- 5.3.2.2 If measurements are made using the method described in Annex 3 using a vehicle-to-antenna spacing of 3.0 ± 0.05 m, the limit shall be 32 dB microvolts/m in the 30 to 75 MHz frequency band and 32 to 43 dB microvolts/m in the 75 to 400 MHz frequency band, this limit increasing logarithmically with frequencies above 75 MHz as shown in Appendix 5. In the 400 to 1,000 MHz frequency band the limit remains constant at 43 dB microvolts/m
- 5.3.2.3 On the vehicle representative of its type, the measured values, expressed in dB microvolts/m, shall be below the type approval limit.
- 5.3.2.4 Notwithstanding the limits defined in paragraphs 5.3.2.1, 5.3.2.2 and 5.3.2.3 of this standard, if, during the initial step described in paragraph 1.3. of Annex 3 , the signal strength measured at the vehicle broadcast radio antenna is less than 20 dB microvolts over the frequency range 76 to 108 MHz measured with an average detector, then the vehicle shall be deemed to comply with the limits for narrowband emissions and no further testing will be required.
- 5.4 **Specifications Concerning Immunity of Vehicles to Electromagnetic Radiation.**
- 5.4.1 Method of Testing
- The immunity to electromagnetic radiation of the vehicle representative of its type shall be tested by the method described in Annex 4.
- 5.4.2 Vehicle Immunity Type Approval Limits.
- 5.4.2.1 If tests are made using the method described in Annex 4, the field strength shall be 30 volts/m rms (root mean squared) in over 90 per cent of the 20 to 2,000 MHz frequency band and a minimum of 25 volts/m rms over the whole 20 to 2,000 MHz frequency band.
- 5.4.2.2 The vehicle representative of its type shall be considered as complying with immunity requirements if, during the tests performed in accordance with Annex 4 , there shall be no degradation of performance of "immunity related functions

5.5 **Specifications Concerning Broadband Electromagnetic Interference Generated by ESAs.**

5.5.1 Method of Measurement

The electromagnetic radiation generated by the ESA representative of its type shall be measured by the method described in Annex 5.

5.5.2 ESA Broadband Type Approval limits

5.5.2.1 If measurements are made using the method described in Annex 5, the limits shall be 62 to 52 dB microvolts/m in the 30 to 75 MHz frequency band, this limit decreasing logarithmically with frequencies above 30 MHz, and 52 to 63 dB microvolts/m in the 75 to 400 MHz band, this limit increasing logarithmically with frequencies above 75 MHz as shown in Appendix 6. In the 400 to 1,000 MHz frequency band the limit remains constant at 63 dB microvolts/m.

5.5.2.2 On the ESA representative of its type, the measured values, expressed in dB microvolts/m, shall be below the type approval limits.

5.6 **Specifications Concerning Narrowband Electromagnetic Interference Generated by ESAs.**

5.6.1 Method of Measurement

The electromagnetic radiation generated by the ESA representative of its type shall be measured by the method described in Annex 6.

5.6.2 ESA narrowband type approval limits

5.6.2.1 If measurements are made using the method described in Annex 6, the limits shall be 52 to 42 dB microvolts/m in the 30 to 75 MHz frequency band, this limit decreasing logarithmically with frequencies above 30 MHz, and 42 to 53 dB microvolts/m in the 75 to 400 MHz band, this limit increasing logarithmically with frequencies above 75 MHz as shown in Appendix 7. In the 400 to 1,000 MHz frequency band the limit remains constant at 53 dB microvolts/m.

5.6.2.2 On the ESA representative of its type, the measured values, expressed in dB microvolts/m, shall be below the type approval limits.

5.7 **Specifications Concerning Immunity of ESAs to Electromagnetic Radiation.**

5.7.1 Method(s) of Testing

The immunity to electromagnetic radiation of the ESA representative of its type shall be tested by the method(s) chosen from those described in Annex 7.

5.7.2 ESA immunity type approval limits

5.7.2.1 If tests are made using the methods described in Annex 7, the immunity test levels shall be 60 volts/m for the 150 mm stripline testing method, 15 volts/m for the 800 mm stripline testing method, 75 volts/m for the Transverse Electromagnetic Mode (TEM) cell testing method, 60 mA for the bulk current injection (BCI) testing method and 30 volts/m for the free field testing method in over 90 per cent of the 20 to 2,000 MHz frequency band, and to a minimum of 50 volts/m for the 150 mm stripline testing method, 12.5 volts/m for the 800 mm stripline testing method, 62.5 volts/m for the TEM cell testing method, 50 mA for the bulk current injection (BCI) testing method and 25 volts/m for the free field testing method over the whole 20 to 2,000 MHz frequency band.

5.7.2.2 The ESA representative of its type shall be considered as complying with immunity requirements if, during the tests performed in accordance with Annex 7, there shall be no degradation of performance of "immunity related functions".

5.8 **Specifications Concerning the Immunity to Transient Disturbances Conducted along Supply Lines.**

5.8.1 Method of testing

The immunity of ESA representative of its type shall be tested by the method(s) according to ISO 7637-2, second edition 2004 as described in Annex 8 with the test levels given in table 1.

Table 1
Immunity of ESA

Test pulse number	Immunity test level	Functional status for systems:	
		Related to immunity related functions	Not related to immunity related functions
1	III	C	D
2a	III	B	D
2b	III	C	D
3a/3b	III	A	D
4	III	B (for ESA which must be operational during engine start phases) C (for other ESA)	D

5.9 Specifications Concerning the Emission of Conducted Disturbances

5.9.1 Method of testing

The emission of ESA representative of its type shall be tested by the method(s) according to ISO 7637-2, second edition 2004 as described in Annex 8 for the levels given in table 2.

Table 2
Maximum allowed pulse amplitude

Polarity of pulse amplitude	Maximum allowed pulse amplitude for	
	Vehicles with 12 V systems	Vehicles with 24 V systems
Positive	+75	+150
Negative	-100	- 450

5.10 Exceptions

5.10.1 Where a vehicle or electrical/electronic system or ESA does not include an electronic oscillator with an operating frequency greater than 9 kHz, it shall be deemed to comply with paragraphs 5.3.2 or 5.6.2 above and to Annexes 3 and 6.

5.10.2 Vehicles which do not have electrical/electronic systems with "immunity related functions" need not be tested for immunity to radiated disturbances and shall be deemed to comply with paragraph 5.4 and with Annex 4 to this standard.

5.10.3 ESAs with no immunity related functions need not be tested for immunity to radiated disturbances and shall be deemed to comply with paragraph 5.7 and with Annex 7 to this standard.

5.10.4 Electrostatic Discharge

For vehicles fitted with tyres, the vehicle body/chassis can be considered to be an electrically isolated structure. Significant electrostatic forces in relation to the vehicle's external environment occur only at the moment of occupant entry into or exit from the vehicle. As the vehicle is stationary at these moments, no type approval test for electrostatic discharge is deemed necessary.

5.10.5 Conducted Emission

ESAs that are not switched, contain no switches or do not include inductive loads need not be tested for conducted emission and shall be deemed to comply with paragraph 5.9.

- 5.10.6 The loss of function of receivers during the immunity test, when the test signal is within the receiver bandwidth (RF exclusion band) as specified for the specific radio service/product in the harmonized international EMC standard, does not necessarily lead to fail criteria.
- 5.10.7 RF transmitters shall be tested in the transmit mode. Wanted emissions (e.g. from RF transmitting systems) within the necessary bandwidth and out of band emissions are disregarded for the purpose of this standard. Spurious emissions are subject to this standard.
- 5.10.7.1 "Necessary Bandwidth": for a given class of emission, the width of the frequency band which is just sufficient to ensure the transmission of information at the rate and with the quality required under specified conditions (Article 1, No. 1.152 of the ITU Radio Regulations).
- 5.10.7.2 "Out-of-band Emissions": Emission on a frequency or frequencies immediately outside the necessary bandwidth which results from the modulation process, but excluding spurious emissions (Article 1, No. 1.144 of the ITU Radio Regulations).
- 5.10.7.3 "Spurious Emission": In every modulation process additional undesired signals exist. They are summarized under the expression "spurious emissions". Spurious emissions are emissions on a frequency or frequencies, which are outside the necessary bandwidth and the level of which may be reduced without affecting the corresponding transmission of information. Spurious emissions include harmonic emissions, parasitic emissions, intermodulation products and frequency conversion products, but exclude out-of-band emissions (Article 1 No. 1.145 of the ITU Radio Regulations)."

6.0 AMENDMENT OR EXTENSION OF A VEHICLE TYPE APPROVAL FOLLOWING ESA ADDITION OR SUBSTITUTION

- 6.1 Where a vehicle manufacturer has obtained type approval for a vehicle installation and wishes to fit an additional or substitutional electrical/electronic system or ESA which has already received approval under this standard, and which will be installed in accordance with any conditions attached thereto, the vehicle approval may be extended without further testing. The additional or substitutional electrical/electronic system or ESA shall be considered as part of the vehicle for conformity of production purposes.
- 6.2 Where the additional or substitutional part(s) has (have) not received approval pursuant to this standard, and if testing is considered necessary, the whole vehicle shall be deemed to conform if the new or revised part(s) can be shown to conform to the relevant requirements of paragraph 5 or if, in a comparative test, the new part can be shown not to be likely to adversely affect the conformity of the vehicle type.

6.3 The addition by a vehicle manufacturer to an approved vehicle of standard domestic or business equipment, other than mobile communication equipment, which conforms to other standards, and the installation, substitution or removal of which is according to the recommendations of the equipment and vehicle manufacturers, shall not invalidate the vehicle approval. This shall not preclude vehicle manufacturers fitting communication equipment in accordance with suitable installation guidelines developed by the vehicle manufacturer and/or manufacturer(s) of such communication equipment. The vehicle manufacturer shall provide evidence (if requested by the Test Agency) that vehicle performance is not adversely affected by such transmitters. This can be a statement that the power levels and installation are such that the immunity levels of this standard offer sufficient protection when subject to transmission alone i.e. excluding transmission in conjunction with the tests specified in paragraph 5. This standard does not authorize the use of a communication transmitter when other requirements on such equipment or its use apply.

7.0 CONFORMITY OF PRODUCTION

7.1 Conformity of Production Procedures of a Vehicle fitted with ESA

7.1.1 A vehicle approved under this standard shall be so manufactured as to conform to the type approved by meeting the relevant requirements set forth in this standard.

7.1.2 Whole vehicle conformity of production procedures shall be applicable as and when notified by the Government (Ministry of Road Transport & Highways).

7.2 Conformity of Production Procedures of an ESA

7.2.1 ESA approved under this standard shall be so manufactured as to conform to the type approved by meeting the relevant requirements set forth in this standard.

7.2.2 Conformity of production procedures as and when notified by the Government (Ministry of Road Transport & Highways) shall be applicable

8.0 MODIFICATION AND EXTENSION OF TYPE APPROVAL OF A VEHICLE OR ESA

8.1 Every modification pertaining to the information, even if the changes are not technical in nature declared in accordance with 3.0, shall be intimated by the manufacturer to the Test Agency.

If the changes are in parameters not related to the provisions, no further action will be taken.

If the changes are in parameters related to the provisions, the testing agency which has issued the certificate of compliance shall then consider whether

8.1.1 The model with the changed specifications still complies with provisions or

8.1.2 Any further verification or testing is required to establish compliance.

8.2 For considering whether testing is required or not, guidelines given in Annex 9A & 9B (Worst Case Criteria (WCC) & Criteria for Extension of Approval) shall be used.

8.3 In case of 8.1.2, tests for only those parameters which are affected by the modifications need to be carried out.

8.4 In case of fulfillment of criterion of para 8.1.1, or after results of further verification as per para 8.1.2 are satisfactory, the approval of compliance shall be extended for the changes carried out.

APPENDIX 1

LIST OF STANDARDS REFERRED TO IN THIS STANDARD

1. CISPR 12 "Vehicles', motorboats' and spark-ignited engine-driven devices' radio disturbance characteristics - Limits and methods of measurement", fifth edition 2001.
2. CISPR 16-1-4 "Specifications for radio disturbance and immunity measuring apparatus and methods - Part 1: Radio disturbance and immunity measuring apparatus", Edition 1.1. 2004.
3. CISPR 25 "Limits and methods of measurement of radio disturbance characteristics for the protection of receivers used on board vehicles", second edition 2002.
4. ISO 7637-1 "Road vehicles - Electrical disturbance from conduction and coupling - Part 1: Definitions and general considerations", second edition 2002.
5. ISO 7637-2 "Road vehicles - Electrical disturbance from conduction and coupling - Part 2: Electrical transient conduction along supply lines only on vehicles with nominal 12 V or 24 V supply voltage", second edition 2004.
6. ISO EN 17025 "General requirements for the competence of testing and calibration laboratories", first edition 1999.
7. ISO 11451 "Road vehicles - Electrical disturbances by narrowband radiated electromagnetic energy - Vehicle test methods":
 Part 1: General and definitions (ISO 11451-1, third edition 2005);
 Part 2: Off-vehicle radiation source (ISO 11451-2, third edition 2005);
 Part 4: Bulk current injection (BCI) (ISO 11451-4, first edition 1995).
8. ISO 11452 "Road vehicles - Electrical disturbances by narrowband radiated electromagnetic energy - Component test methods":
 Part 1: General and definitions (ISO 11452-1, third edition 2005);
 Part 2: Absorber-lined chamber (ISO 11452-2, second edition 2004);
 Part 3: Transverse electromagnetic mode (TEM) cell (ISO 11452-3, third edition 2001);
 Part 4: Bulk current injection (BCI) (ISO 11452-4, third edition 2005);
 Part 5: Stripline (ISO 11452-5, second edition 2002).
9. ITU Radio Regulations, edition 2001.

APPENDIX 2

VEHICLE BROADBAND REFERENCE LIMITS

Antenna-Vehicle Separation: 10 m

Limit E (dB μ V/m) at frequency F (MHz)		
30 - 75 MHz	75 - 400 MHz	400 - 1,000 MHz
E = 32	$E = 32 + 15.13 \log (F/75)$	E = 43

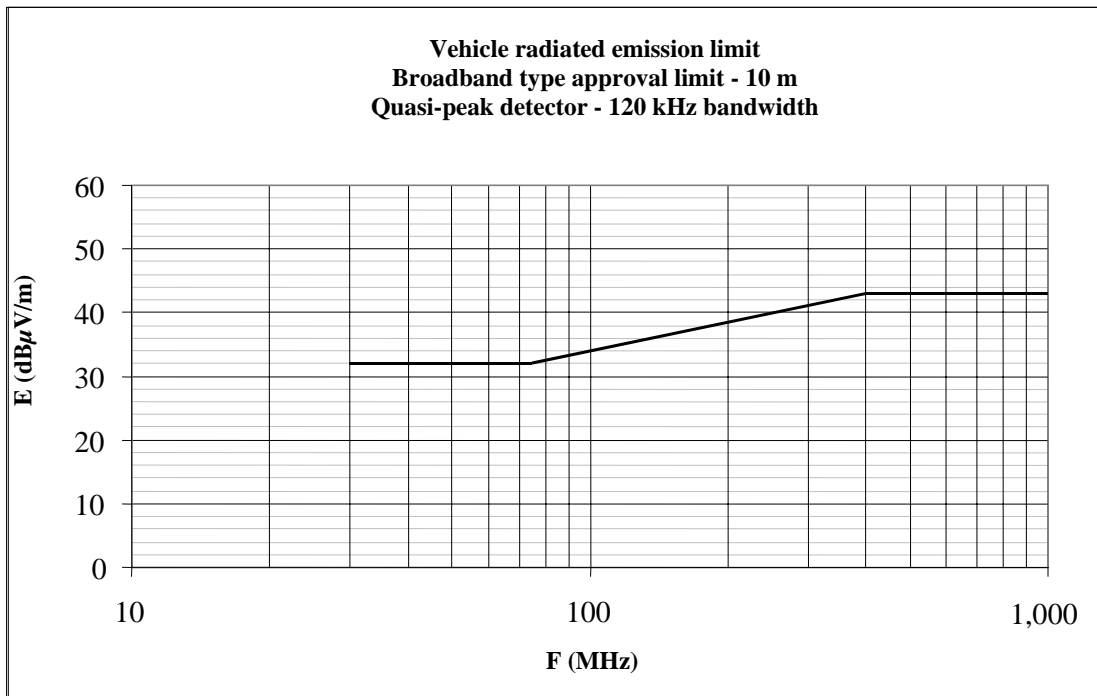

Frequency - megahertz - logarithmic

(See paragraph 5.2.2.1 of this standard)

APPENDIX 3

VEHICLE BROADBAND REFERENCE LIMITS

Antenna-Vehicle Separation: 3 m

Limit E (dB μ V/m) at frequency F (MHz)		
30 - 75 MHz	75 - 400 MHz	400 - 1,000 MHz
E = 42	$E = 42 + 15.13 \log (F/75)$	E = 53

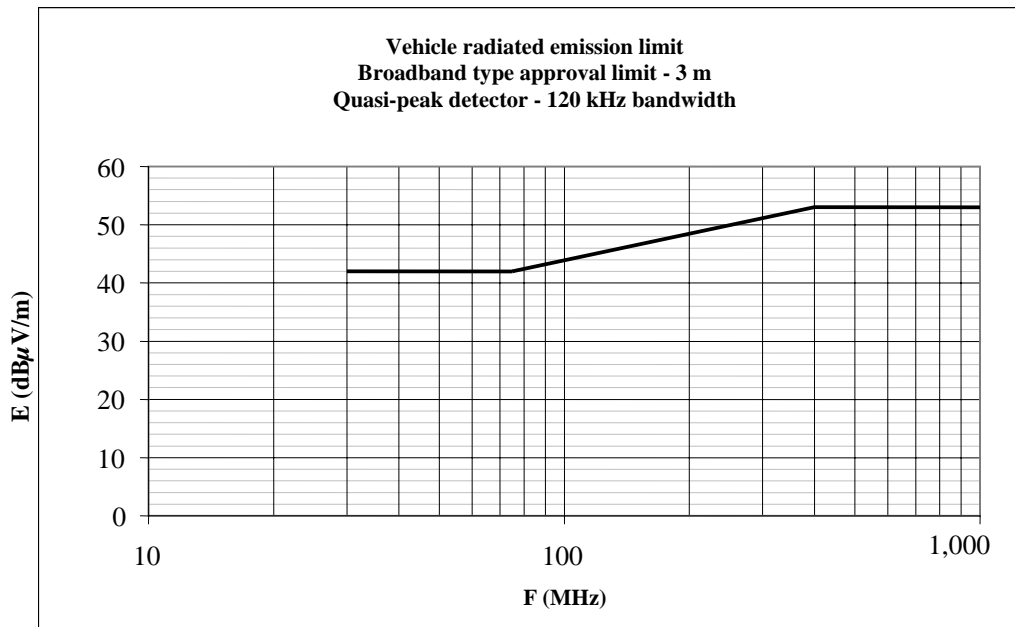

Frequency - megahertz - logarithmic

(See paragraph 5.2.2.2 of this standard)

APPENDIX 4

VEHICLE NARROWBAND REFERENCE LIMITS

Antenna-Vehicle Separation: 10 m

Limit E (dB μ V/m) at frequency F (MHz)		
30 - 75 MHz	75 - 400 MHz	400 - 1,000 MHz
E = 22	$E = 22 + 15.13 \log (F/75)$	E = 33

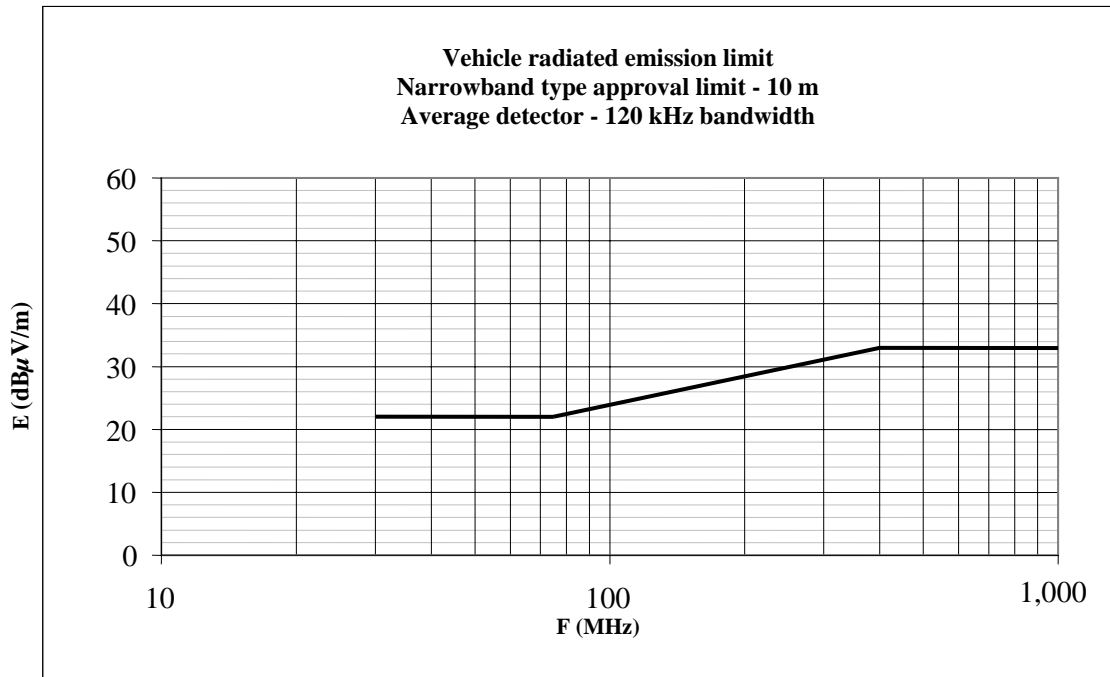

Frequency - megahertz - logarithmic

(See paragraph 5.3.2.1 of this standard)

APPENDIX 5

VEHICLE NARROWBAND REFERENCE LIMITS

Antenna-Vehicle Separation: 3 m

Limit E (dB μ V/m) at frequency F (MHz)		
30 - 75 MHz	75 - 400 MHz	400 - 1,000 MHz
E = 32	$E = 32 + 15.13 \log (F/75)$	E = 43

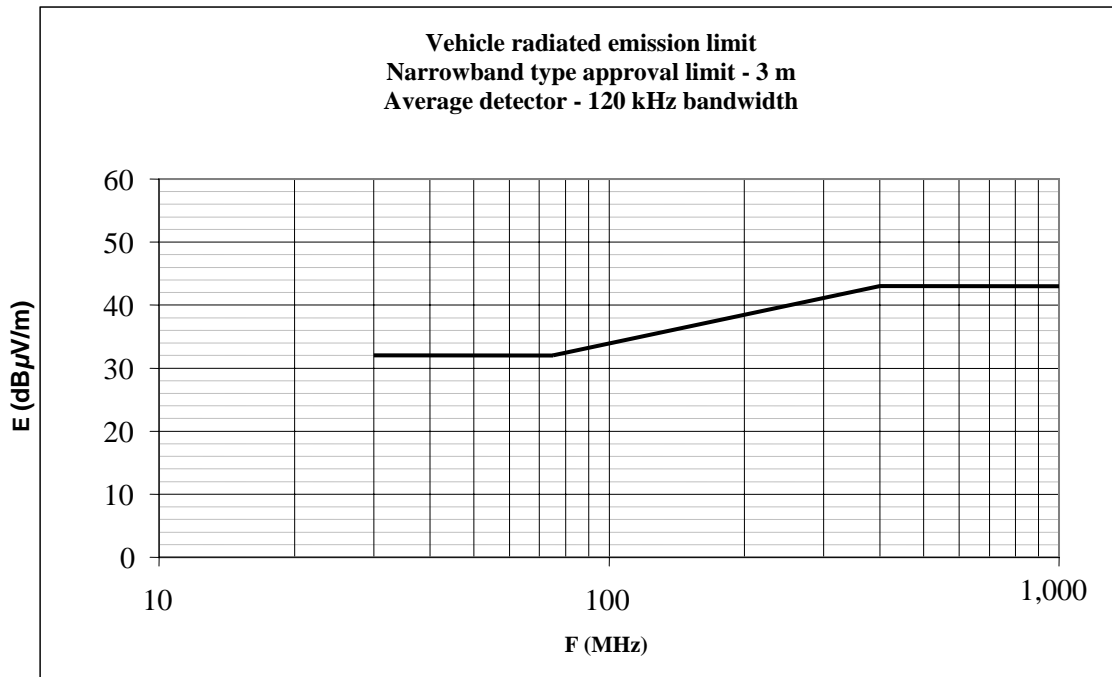

Frequency - megahertz - logarithmic

(See paragraph 5.3.2.2 of this standard)

APPENDIX 6

ELECTRICAL/ELECTRONIC SUB-ASSEMBLY

Broadband Reference Limits

Limit E (dB μ V/m) at frequency F (MHz)		
30 - 75 MHz	75 - 400 MHz	400 - 1,000 MHz
$E = 62 - 25.13 \log (F/30)$	$E = 52 + 15.13 \log (F/75)$	$E = 63$

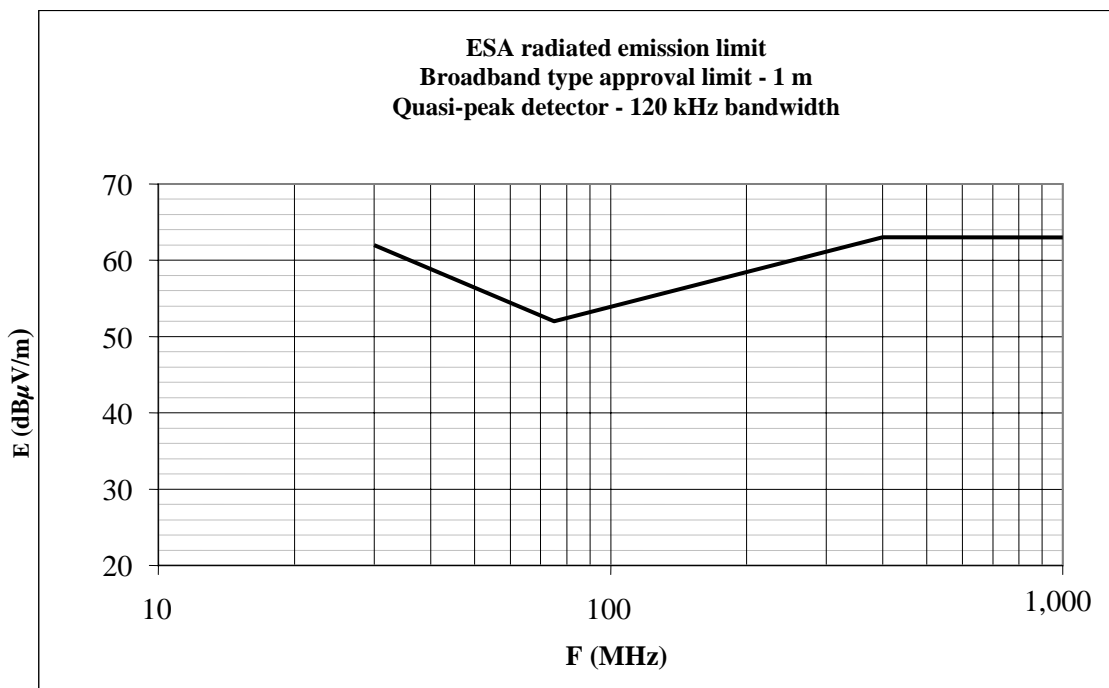

Frequency - megahertz - logarithmic

(See paragraph 5.5.2.1 of this standard)

APPENDIX 7

ELECTRICAL/ELECTRONIC SUB-ASSEMBLY

Narrow band Reference Limits

Limit E (dBμV/m) at frequency F (MHz)		
30 - 75 MHz	75 - 400 MHz	400 - 1,000 MHz
$E = 52 - 25.13 \log (F/30)$	$E = 42 + 15.13 \log (F/75)$	$E = 53$

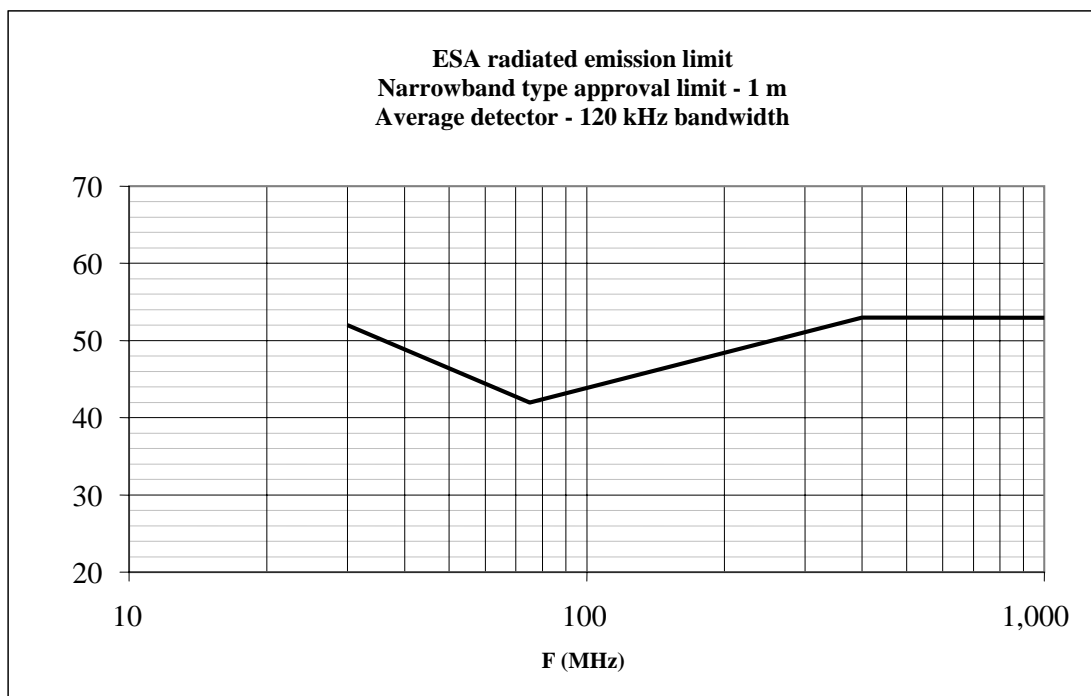

Frequency - megahertz - logarithmic

(See paragraph 5.6.2.1 of this standard)

ANNEX 1A

(See 3.1.2)

**TECHNICAL SPECIFICATIONS FOR TYPE-APPROVAL OF
A VEHICLE WITH RESPECT TO
ELECTROMAGNETIC COMPATIBILITY**

The following information, if applicable, shall be supplied in triplicate and shall include a list of contents.

Any drawings shall be supplied in appropriate scale and in sufficient detail on size A 4 or in a folder of A4 format.

Photographs, if any, shall show sufficient detail.

If the systems, components or separate technical units have electronic controls, information concerning their performance shall be supplied.

GENERAL

1. Make (trade name of manufacturer):
2. Type:
3. Category of vehicle:
4. Name and address of manufacturer:
- Name and address of authorised representative, if any:
5. Address (es) of assembly plant(s):

GENERAL CONSTRUCTION CHARACTERISTICS OF THE VEHICLE

6. Photograph(s) and/or drawing(s) of a representative vehicle:
7. Position and arrangement of the engine:

POWER PLANT

8. Manufacturer:
9. Manufacturer's engine code as marked on the engine:
10. Internal combustion engine:
11. Working principle: positive ignition/compression ignition, four-stroke/two stroke.....
12. Number and arrangement of cylinders:
13. Fuel feed:
14. By fuel injection (compression ignition only): yes/no
15. Electronic control unit:
16. Make(s):

17. Description of the system:
18. By fuel injection (positive ignition only): yes/no
19. Electrical system:
20. Rated voltage: V, positive/negative ground
21. Generator:
22. Type:
23. Ignition:
24. Make(s):
25. Type(s):
26. Working principle:
27. LPG fuelling system: yes/no
28. Electronic engine management control unit for LPG fuelling:
29. Make(s):
30. Type(s):
31. CNG fuelling system: yes/no
32. Electronic engine management control unit for CNG fuelling:
33. Make(s):
34. Type(s):
35. Electric motor:
36. Type (winding, excitation):
37. Operating voltage:

Gas fuelled engines (in the case of systems laid-out in a different manner,
supply equivalent information)
38. Electronic control unit (ECU):
39. Make(s):

- 40. Type(s):
TRANSMISSION
- 41. Type (mechanical, hydraulic, electric, etc.):
- 42. A brief description of the electrical/electronic components (if any):
SUSPENSION
- 43. A brief description of the electrical/electronic components (if any):
STEERING
- 44. A brief description of the electrical/electronic components (if any):
BRAKES
- 45. Anti-lock braking system: yes/no/optional
- 46. For vehicles with anti-lock systems, description of system operation (including any electronic parts), electric block diagram, hydraulic or pneumatic circuit plan:
BODYWORK
- 47. Type of bodywork:
- 48. Materials used and methods of construction:
- 49. Windscreen and other windows:
A brief description of the electrical/electronic components (if any) of the window lifting mechanism:
- 50. Rear-view mirrors (state for each mirror):
A brief description of the electronic components (if any) of the adjustment system:
- 51. Safety belts and/or other restraint systems:
- 52. A brief description of the electrical/electronic components (if any):
- 53. Suppression of radio interference:
- 54. Description and drawings/photographs of the shapes and constituent materials of the part of the body forming the engine compartment and the part of the passenger compartment nearest to it:

- 55. Drawings or photographs of the position of the metal components housed in the engine compartment (e.g. heating appliances, spare wheel, air filter, steering mechanism, etc.):
- 56. Table and drawing of radio interference control equipment:
- 57. Particulars of the nominal value of the direct current resistance and, in the case of resistive ignition cables, of their nominal resistance per meter:

LIGHTING AND LIGHT SIGNALLING DEVICES

- 58. A brief description of electrical/electronic components other than lamps (if any):

MISCELLANEOUS

- 59. Devices to prevent unauthorised use of the vehicle:
- 60. A brief description of the electrical/electronic components (if any):
- 61. Table of installation and use of RF transmitters in the vehicle(s), if applicable (see paragraph 3.1.8. of this Stanadrd):

frequency bands [Hz]	max. output power [W]	antenna position at vehicle, specific conditions for installation and/or use

- 62. Vehicle equipped with 24 GHz short-range radar equipment: yes/no/optional

The application for type approval shall also include, where appropriate:

Appendix 1:

A list with make(s) and type(s) of all electrical and/or electronic components concerned by this standard (see paragraphs 2.9. and 2.10. of this standard) and not previously listed.

Appendix 2:

Schematics or drawing of the general arrangement of electrical and/or electronic components (concerned by this Regulation) and the general wiring harness arrangement.

Appendix 3:

Description of vehicle chosen to represent the type:

Body style:

Wheelbase:

Appendix 4:

Relevant test report(s) supplied by the manufacturer from a test laboratory accredited to ISO 17025 and recognized by the Test Agency for the purpose of drawing up the type approval certificate.

ANNEX 1B

(See 3.2.3)

**TECHNICAL SPECIFICATIONS FOR TYPE-APPROVAL OF
AN ELECTRIC/ELECTRONIC SUB-ASSEMBLY WITH RESPECT
TO ELECTROMAGNETIC COMPATIBILITY**

The following information, if applicable, shall be supplied in triplicate and must include a list of contents. Any drawings shall be supplied in appropriate scale and in sufficient detail on size A4 or on a folder of A4 format. Photographs, if any, shall show sufficient detail.

If the systems, components or separate technical units have electronic controls, information concerning their performance shall be supplied.

1. Make (trade name of manufacturer):
2. Type:
3. Means of identification of type, if marked on the component/separate technical unit:
 - 3.1. Location of that marking:
4. Name and address of manufacturer:
 Name and address of authorized representative, if any:
5. In the case of components and separate technical units, location and method of affixing of the approval mark:
6. Address(s) of assembly plant(s):
7. This ESA shall be approved as a component/STU
8. Any restrictions of use and conditions for fitting:
9. Electrical system rated voltage: V, positive/negative 2/ ground.

Appendix 1:

Description of the ESA chosen to represent the type (electronic block diagram and list of main component constituting the ESA (e.g. make and type of microprocessor, crystal, etc.).

Appendix 2:

Relevant test report(s) supplied by the manufacturer from a test laboratory accredited to ISO 17025 and recognized by the Test Agency for the purpose of drawing up the type approval certificate."

ANNEX 2

(See 5.2.1)

**METHOD OF MEASUREMENT OF RADIATED BROADBAND
ELECTROMAGNETIC EMISSIONS FROM VEHICLES****1. GENERAL**

1.1. The test method described in this Annex shall only be applied to vehicles.

1.2 Test Method

This test is intended to measure the broadband emissions generated by electrical or electronic systems fitted to the vehicle (e.g. ignition system or electric motors).

If not otherwise stated in this annex the test shall be performed according to CISPR 12 (Amendment 1 fifth edition 2005).

2. VEHICLE STATE DURING TESTS

2.1. For vehicles equipped with an internal combustion engine, the engine shall be in operation according to CISPR 12 (amendment 1, fifth edition 2005) clause 5.3.2. Typically for single cylinder engines, the engine speed shall be $2500 \pm 10\%$ rpm and for multi-cylinder (>1 cylinder) engines, the engine speed shall be $1500 \pm 10\%$ rpm.

For vehicles equipped with an electric propulsion motor, the vehicle shall be driven on a dynamometer without a load, or on non-conductive axle stands, with a constant speed of 40 km/h, or the maximum speed, if this is less than 40 km/h.

2.2. Other vehicle systems

All equipment capable of generating broadband emissions which can be switched on permanently by the driver or passenger should be in operation in maximum load, e.g. wiper motors or fans. The horn and electric window motors are excluded because they are not used continuously.

3. MEASURING LOCATION

3.1 As an alternative to the requirements of CISPR 12 (amendment 1, fifth edition 2005) for vehicles of category L the test surface may be any location that fulfils the conditions shown in the figure 1 in the appendix to this annex. In this case the measuring equipment must lie outside the part shown in the figures 1 and 2 of Appendix 1 to this annex.

3.2 Enclosed test facilities may be used if correlation can be shown between the results obtained in the enclosed test facility and those obtained at an outdoor site. Enclosed test facilities do not need to meet the dimensional requirements of the outdoor site other than the distance from the antenna to the vehicle and the height of the antenna.

4. TEST REQUIREMENTS

4.1. The limits apply throughout the frequency range 30 to 1,000 MHz for measurements performed in a semi anechoic chamber or an outdoor test site.

4.2. Measurements can be performed with either quasi-peak or peak detectors. The limits given in paragraphs 5.2 and 5.5 of this standard are for quasi-peak detectors. If peak detectors are used a correction factor of 20 dB as defined in CISPR 12 (amendment 1, fifth edition 2005) shall be applied.

4.3. Measurements

The Test Agency shall perform the test at the intervals specified in the CISPR 12 (amendment 1, fifth edition 2005) standard throughout the frequency range 30 to 1,000 MHz.

Alternatively, if the manufacturer provides measurement data for the whole frequency band from a test laboratory accredited to the applicable parts of ISO 17025 (first edition 1999) and recognized by the Test Agency, the Test Agency may divide the frequency range in 14 frequency bands 30 – 34, 34 – 45, 45 – 60, 60 – 80, 80 – 100, 100 – 130, 130 – 170, 170 – 225, 225 – 300, 300–400, 400 – 525, 525 – 700, 700 – 850, 850 – 1,000 MHz and perform tests at the 14 frequencies giving the highest emission levels within each band to confirm that the vehicle meets the requirements of this annex.

In the event that the limit is exceeded during the test, investigations shall be made to ensure that this is due to the vehicle and not due to background radiation.

4.4. Readings

The maximum of the readings relative to the limit (horizontal and vertical polarization and antenna location on the left and right-hand sides of the vehicle) in each of the 14 frequency bands shall be taken as the characteristic reading at the frequency at which the measurements were made.

ANNEX 2 - APPENDIX 1

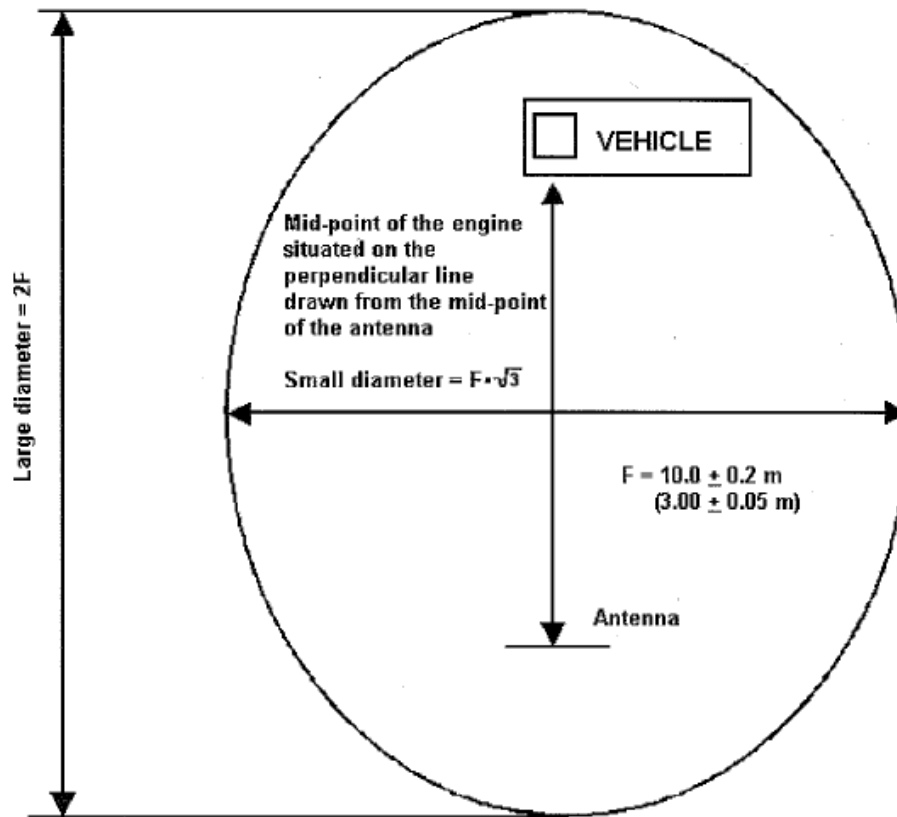
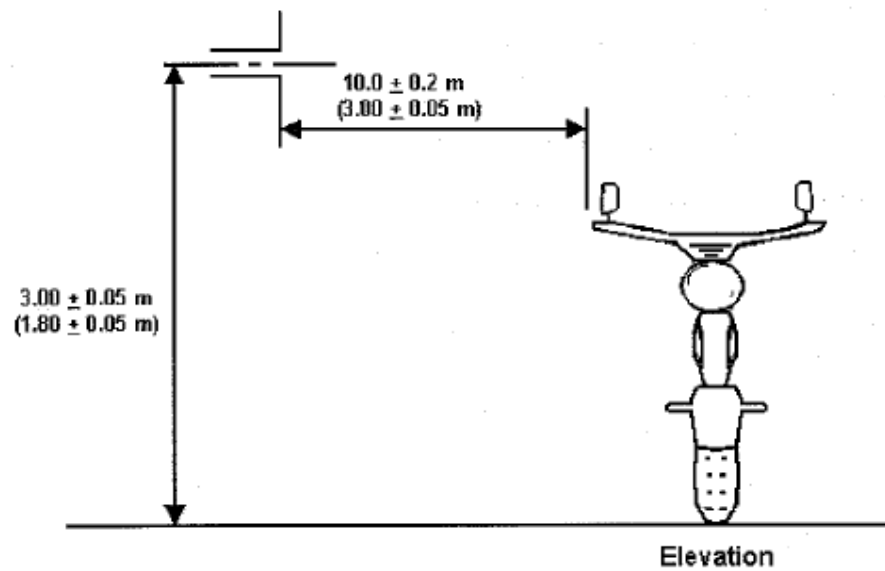

Figure 1

**Clear Horizontal Surface Free of Electromagnetic Reflection
Delimitation of the Surface Defined by an Ellipse**

ANNEX 2 – APPENDIX 1 (cont'd)



Dipole antenna in position to measure the vertical radiation components

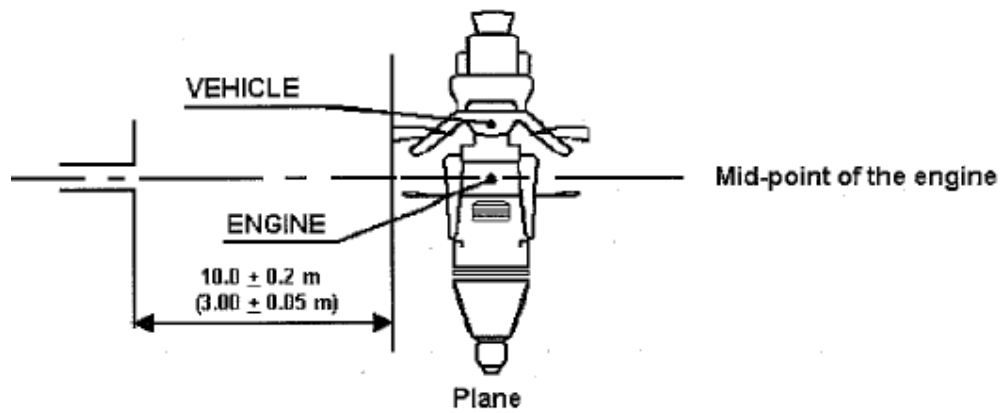

Dipole antenna in position to measure the horizontal radiation components

Figure 2

Position of Antenna in Relation to the Vehicle

ANNEX 3

(See 5.3.1)

**METHOD OF MEASUREMENT OF RADIATED NARROWBAND
ELECTROMAGNETIC EMISSIONS FROM VEHICLES****1. GENERAL**

1.1. The test method described in this annex shall only be applied to vehicles.

1.2 Test Method

This test is intended to measure the narrowband electromagnetic emissions such as might emanate from microprocessor-based systems or other narrowband source.

If not otherwise stated in this annex the test shall be performed according to CISPR 12 (amendment 1, fifth edition 2005) or to CISPR 25 (second edition 2002).

1.3. As an initial step the levels of emissions in the FM frequency band (76 to 108 MHz) shall be measured at the vehicle broadcast radio antenna with an average detector. If the level specified in paragraph 5.3.2.4 of this standard is not exceeded, then the vehicle shall be deemed to comply with the requirements of this annex in respect of that frequency band and the full test shall not be carried out.

1.4. As an alternative for vehicles of category L the measurement location can be chosen according to Annex 2, paragraphs 3.1 and 3.2.

2. VEHICLE STATE DURING TESTS

2.1. The ignition switch shall be switched on. The engine shall not be operating.

2.2. The vehicle's electronic systems shall all be in normal operating mode with the vehicle stationary.

2.3. All equipment which can be switched on permanently by the driver or passenger with internal oscillators > 9 kHz or repetitive signals should be in normal operation.

3. TEST REQUIREMENTS

3.1. The limits apply throughout the frequency range 30 to 1,000 MHz for measurements performed in a semi anechoic chamber or an outdoor test site.

3.2. Measurements shall be performed with an average detector.

3.3. Measurements

The Test Agency shall perform the test at the intervals specified in the CISPR 12 (amendment 1, fifth edition 2005) standard throughout the frequency range 30 to 1,000 MHz.

Alternatively, if the manufacturer provides measurement data for the whole frequency band from a test laboratory accredited to the applicable parts of ISO 17025 (first edition 1999) and recognized by the Test Agency, the Test Agency may divide the frequency range in 14 frequency bands 30 – 34, 34 – 45, 45 – 60, 60 – 80, 80 – 100, 100 – 130, 130 – 170, 170 – 225, 225 – 300, 300– 400, 400 – 525, 525 – 700, 700 – 850, 850 – 1,000 MHz and perform tests at the 14 frequencies giving the highest emission levels within each band to confirm that the vehicle meets the requirements of this annex.

In the event that the limit is exceeded during the test, investigations shall be made to ensure that this is due to the vehicle and not due to background radiation including broadband radiation from any ESA.

3.4. Readings

The maximum of the readings relative to the limit (horizontal and vertical polarization and antenna location on the left and right-hand sides of the vehicle) in each of the 14 frequency bands shall be taken as the characteristic reading at the frequency at which the measurements were made.

ANNEX 4

(See 5.4.1)

**METHOD OF TESTING FOR IMMUNITY OF VEHICLES TO
ELECTROMAGNETIC RADIATION****1. GENERAL**

1.1. The test method described in this annex shall only be applied to vehicles.

1.2. Test Method

This test is intended to demonstrate the immunity of the vehicle electronic systems. The vehicle shall be subjected to electromagnetic fields as described in this annex. The vehicle shall be monitored during the tests.

If not otherwise stated in this annex the test shall be performed according to ISO 11451-2, third edition 2005.

1.3. Alternative test methods

The test may be alternatively performed in an outdoor test site for all vehicles. The test facility shall comply with (national) legal requirements regarding the emission of electromagnetic fields.

If a vehicle is longer than 12 m and/or wider than 2.60 m and/or higher than 4.00 m, BCI (bulk current injection) method according to ISO 11451-4 (first edition 1995) can be used in the frequency range 20 to 2,000 MHz with levels defined in paragraph 5.7.2.1 of this standard.

2. VEHICLE STATE DURING TESTS

2.1 The vehicle shall be in an unladen condition except for necessary test equipment.

2.1.1. The engine shall normally turn the driving wheels at a steady speed of 50 km/h if there is no technical reason due to the vehicle to define a different condition. For vehicles of categories L1 and L2 the steady speed shall normally be turned at 25 km/h. The vehicle shall be on an appropriately loaded dynamometer or alternatively supported on insulated axle stands with minimum ground clearance if no dynamometer is available. Where appropriate, transmission shafts, belts or chains may be disconnected (e.g. trucks, two- and three wheel vehicles).

2.1.2. Basic vehicle conditions

The paragraph defines minimum test conditions (as far as applicable) and failures criteria for vehicle immunity tests. Other vehicle systems, which can affect immunity related functions must be tested in a way to be agreed between manufacturer and Test Agency.

"50 km/h cycle" vehicle test conditions	Failure criteria
Vehicle speed 50 km/h (respectively 25 km/h for L1, L2 vehicles) ± 20 per cent (vehicle driving the rollers). If the vehicle is equipped with a cruise control system, it shall be operational.	Speed variation greater than ± 10 per cent of the nominal speed. In case of automatic gearbox: change of gear ratio inducing a speed variation greater than ± 10 per cent of the nominal speed.
Dipped beams ON (manual mode)	Lighting OFF
Front wiper ON (manual mode) maximum speed	Complete stop of front wiper
Direction indicator on driver's side ON	Frequency change (lower than 0.75 Hz or greater than 2.25 Hz). Duty cycle change (lower than 25 per cent or greater than 75 per cent).
Adjustable suspension in normal position	Unexpected significant variation
Driver's seat and steering wheel in medium position	Unexpected variation greater than 10 per cent of total range
Alarm unset	Unexpected activation of alarm
Horn OFF	Unexpected activation of horn
Airbag and safety restraint systems operational with inhibited passenger airbag if this function exists	Unexpected activation
Automatic doors closed	Unexpected opening
Adjustable endurance brake lever in normal position	Unexpected activation

"Brake cycle" vehicle test conditions	Failure criteria
To be defined in brake cycle test plan. This must include operation of the brake pedal (unless there are technical reasons not to do so) but not necessarily an anti-lock brake system action.	Stop lights inactivated during cycle Brake warning light ON with loss of function. Unexpected activation

2.1.3. All equipment which can be switched on permanently by the driver or passenger should be in normal operation.

2.1.4. All other systems which affect the driver's control of the vehicle shall be (on) as in normal operation of the vehicle.

- 2.2. If there are vehicle electrical/electronic systems which form an integral part of the direct control of the vehicle, which will not operate under the conditions described in paragraph 2.1., it will be permissible for the manufacturer to provide a report or additional evidence to the Test Agency that the vehicle electrical/electronic system meets the requirements of this standard. Such evidence shall be retained in the type approval documentation.
- 2.3. Only non-perturbing equipment shall be used while monitoring the vehicle. The vehicle exterior and the passenger compartment shall be monitored to determine whether the requirements of this annex are met (e.g. by using (a) video camera(s), a microphone, etc.).

3. REFERENCE POINT

- 3.1. For the purposes of this annex, the reference point is the point at which the field strength shall be established and shall be defined as follows:
- 3.2. For category M, N, T vehicles according to ISO 11451-2, third edition 2005.
- 3.3. For category L vehicles:
 - 3.3.1. at least 2 m horizontally from the antenna phase centre or at least 1 m vertically from the radiating elements of a transmission-line-system (TLS);
 - 3.3.2. on the vehicle's centre line (plane of longitudinal symmetry);
 - 3.3.3. at a height of 1.0 ± 0.05 m above the plane on which the vehicle rests or 2.0 ± 0.05 m if the minimum height of the roof of any vehicle in the model range exceeds 3.0 m,
 - 3.3.4. either at 1.0 ± 0.2 m behind the vertical centerline of the vehicle's front wheel (point C in figure 1 of Appendix 1 to this annex) in the case of three-wheeled vehicles,

or at 0.2 ± 0.2 m behind the vertical centerline of the vehicle's front wheel (point D in figure 2 of Appendix 1 to this annex) in the case of two-wheeled vehicles.
 - 3.3.5. If it is decided to radiate the rear of the vehicle, the reference point shall be established as in paragraphs 3.3.1. to 3.3.4. The vehicle shall then be installed facing away from the antenna and positioned as if it had been horizontally rotated 180 around its centre point, i.e. such that the distance from the antenna to the nearest part of the outer body of the vehicle remains the same. This is illustrated in figure 3 of Appendix 1 to this annex.

4. TEST REQUIREMENTS

4.1. Frequency range, dwell times, polarization

The vehicle shall be exposed to electromagnetic radiation in the 20 to 2,000 MHz frequency ranges in vertical polarization.

The test signal modulation shall be:

(a) AM (amplitude modulation), with 1 kHz modulation and 80 percent modulation depth in the 20 to 800 MHz frequency range, and

(b) PM (pulse modulation), t_{on} 577 μ s, period 4,600 μ s in the 800 to 2,000 MHz frequency range,

if not otherwise agreed between Test Agency and vehicle manufacturer.

Frequency step size and dwell time shall be chosen according to ISO 11451-1, third edition 2005.

- 4.1.1. The Test Agency shall perform the test at the intervals specified in ISO 11451-1, third edition 2005 throughout the frequency range 20 to 2,000 MHz.

Alternatively, if the manufacturer provides measurement to data for the whole frequency band from a test laboratory accredited to the applicable parts of ISO 17025 (first edition 1999) and recognized by the Test Agency, the Test Agency may choose a reduced number of spot frequencies in the range, e.g. 27, 45, 65, 90, 120, 150, 190, 230, 280, 380, 450, 600, 750, 900, 1,300, and 1,800 MHz to confirm that the vehicle meets the requirements of this annex.

If a vehicle fails the test defined in this annex, it must be verified as having failed under the relevant test conditions and not as a result of the generation of uncontrolled fields.

5 GENERATION OF REQUIRED FIELD STRENGTH

5.1. Test methodology

- 5.1.1. The substitution method according to ISO 11451-1, third edition 2005 shall be used to establish the test field conditions.

5.1.2. Calibration

For TLS one field probe at the facility reference point shall be used.

For antennas four field probes at the facility reference line shall be used.

5.1.3. Test phase

The vehicle shall be positioned with the centre line of the vehicle on the facility reference point or line. The vehicle shall normally face a fixed antenna. However, where the electronic control units and the associated wiring harness are predominantly in the rear of the vehicle, the test should normally be carried out with the vehicle facing away from the antenna. In the case of long vehicles (i.e. excluding vehicles of categories L, M1 and N1), which have electronic control units and associated wiring harness predominantly towards the middle of the vehicle, a reference point may be established based on either the right side surface or the left side surface of the vehicle. This reference point shall be at the midpoint of the vehicle's length or at one point along the side of the vehicle chosen by the manufacturer in conjunction with the Test Agency after considering the distribution of electronic systems and the layout of any wiring harness.

Such testing may only take place if the physical construction of the chamber permits. The antenna location must be noted in the test report.

ANNEX 4 – APPENDIX 1

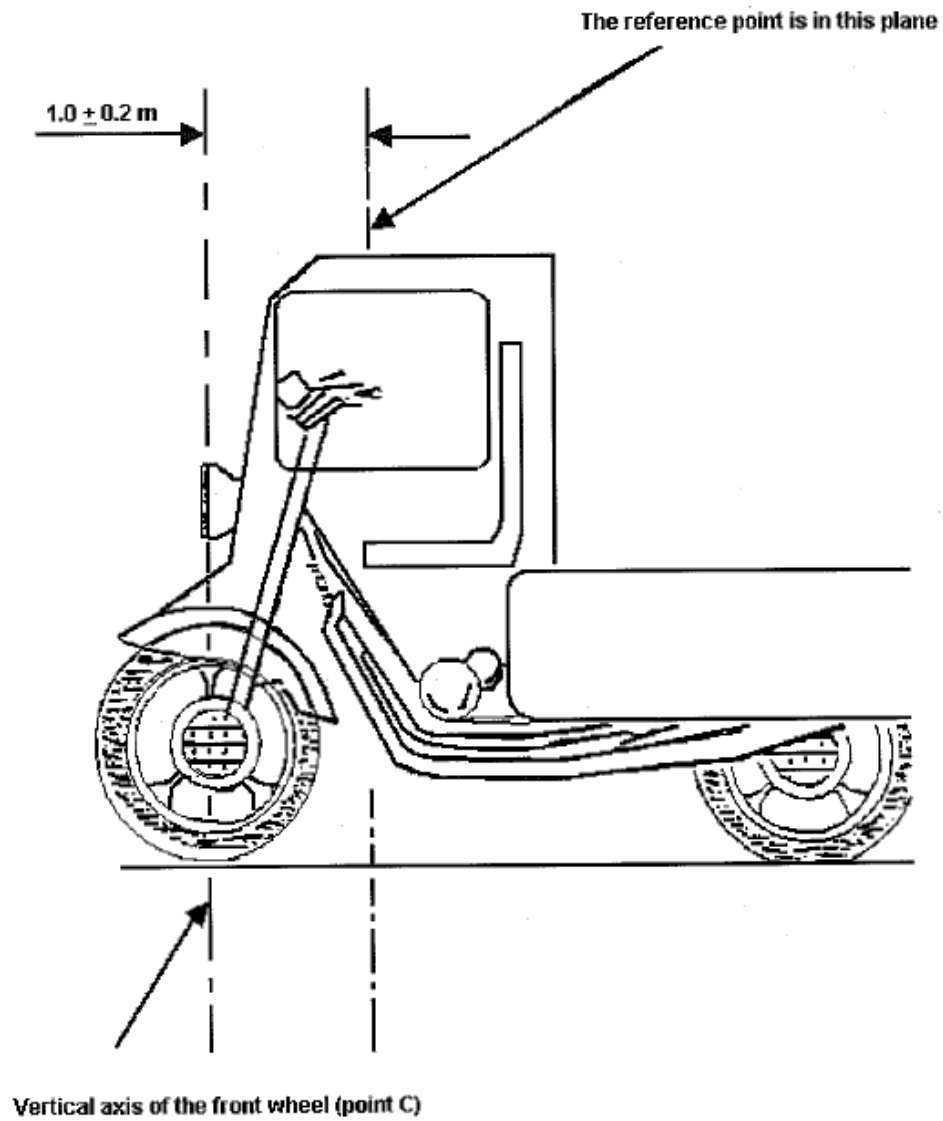

Figure 1

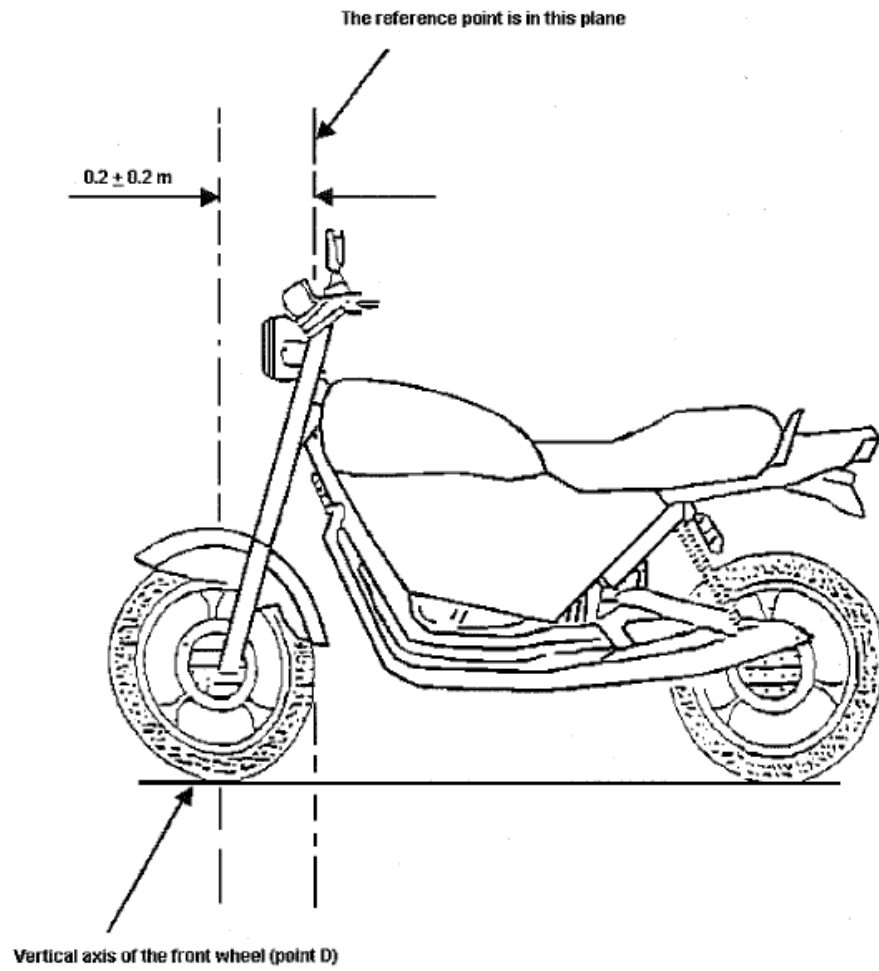

Figure 2

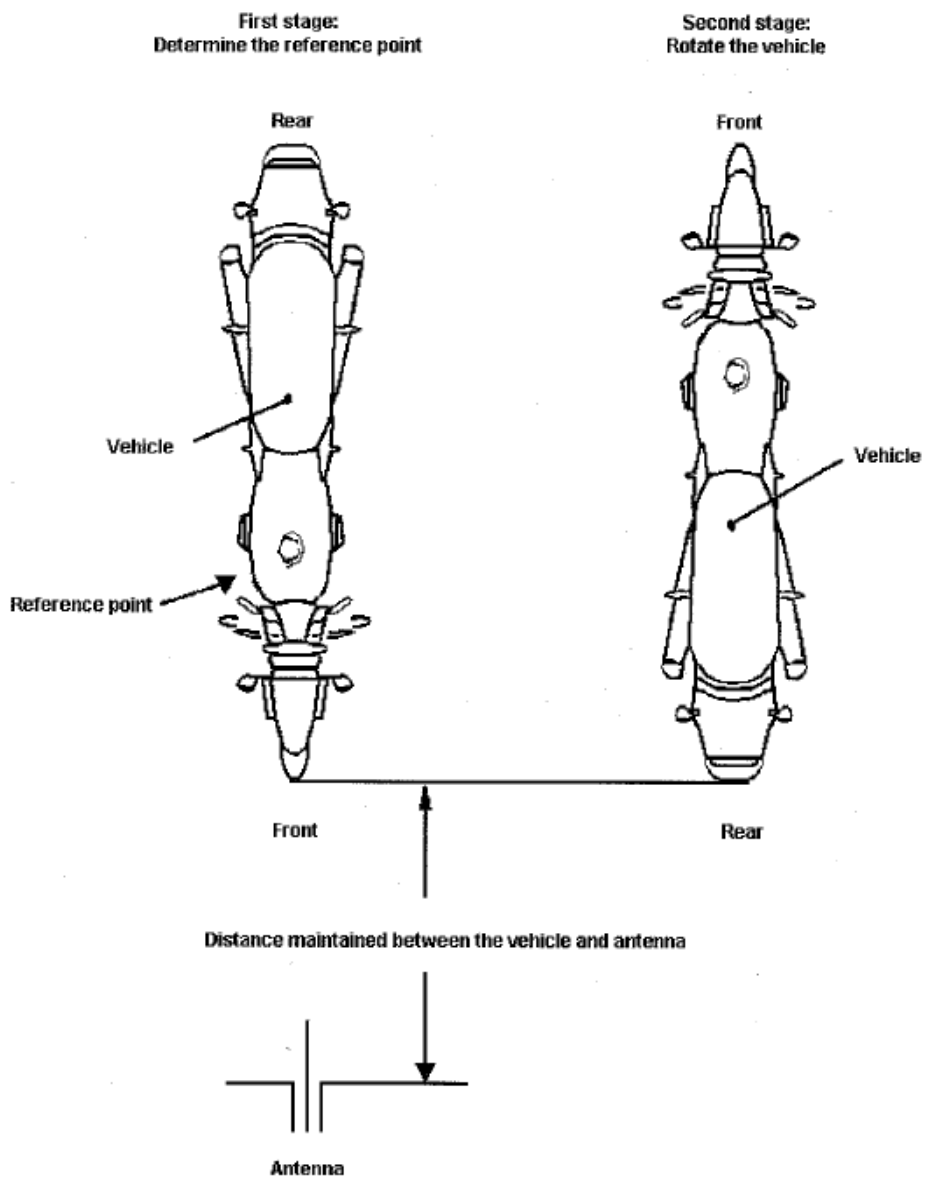

Figure 3

ANNEX 5

(See 5.5.1)

**METHOD OF MEASUREMENT OF
RADIATED BROADBAND ELECTROMAGNETIC EMISSIONS
FROM ELECTRICAL/ELECTRONIC SUB-ASSEMBLIES****1. GENERAL**

- 1.1. The test method described in this annex may be applied to ESAs which may be subsequently fitted to vehicles, which comply with Annex 2.

1.2. Test method

This test is intended to measure broadband electromagnetic emissions from ESAs (e.g. ignition systems, electric motor, etc.).

If not otherwise stated in this annex the test shall be performed according to CISPR 25 (second edition 2002).

2. ESA STATE DURING TESTS

- 2.1. The ESA under test shall be in normal operation mode, preferably in maximum load.

3. TEST ARRANGEMENTS

- 3.1. The test shall be performed according to CISPR 25 (second edition 2002) clause 6.4. - ALSE method.

3.2. Alternative measuring location

As an alternative to an absorber lined shielded enclosure (ALSE) an open area test site (OATS), which complies with the requirements of CISPR 16-1 (second edition 2002) may be used (see Appendix 1 of this annex).

3.3. Ambient

To ensure that there is no extraneous noise or signal of a magnitude sufficient to affect materially the measurement, measurements shall be taken before or after the main test. In this measurement, the extraneous noise or signal shall be at least 6 dB below the limits of interference given in paragraph 5.5.2.1 of this standard, except for intentional narrowband ambient transmissions.

4. TEST REQUIREMENTS

- 4.1. The limits apply throughout the frequency range 30 to 1,000 MHz for measurements performed in a semi anechoic chamber or an outdoor test site.

4.2. Measurements can be performed with either quasi-peak or peak detectors. The limits given in paragraphs 5.2 and 5.5 of this standard are for quasi-peak detectors. If peak detectors are used a correction factor of 20 dB as defined in CISPR 12 (fifth edition 2001) shall be applied.

4.3. Measurements

The Test Agency shall perform the test at the intervals specified in the CISPR 25 (second edition 2002) standard throughout the frequency range 30 to 1,000 MHz.

Alternatively, if the manufacturer provides measurement data for the whole frequency band from a test laboratory accredited to the applicable parts of ISO 17025 (first edition 1999) and recognized by the Test Agency, the Test Agency may divide the frequency range in 13 frequency bands 30–50, 50-75, 75-100, 100-130, 130-165, 165-200, 200-250, 250-320, 320-400, 400-520, 520-660, 660-820, 820-1,000 MHz and perform tests at the 13 frequencies giving the highest emission levels within each band to confirm that the ESA meets the requirements of this annex.

In the event that the limit is exceeded during the test, investigations shall be made to ensure that this is due to the ESA and not to background radiation.

4.4. Readings

The maximum of the readings relative to the limit (horizontal/vertical polarization) in each of the 13 frequency bands shall be taken as the characteristic reading at the frequency at which the measurements were made.

ANNEX 5 - APPENDIX 1

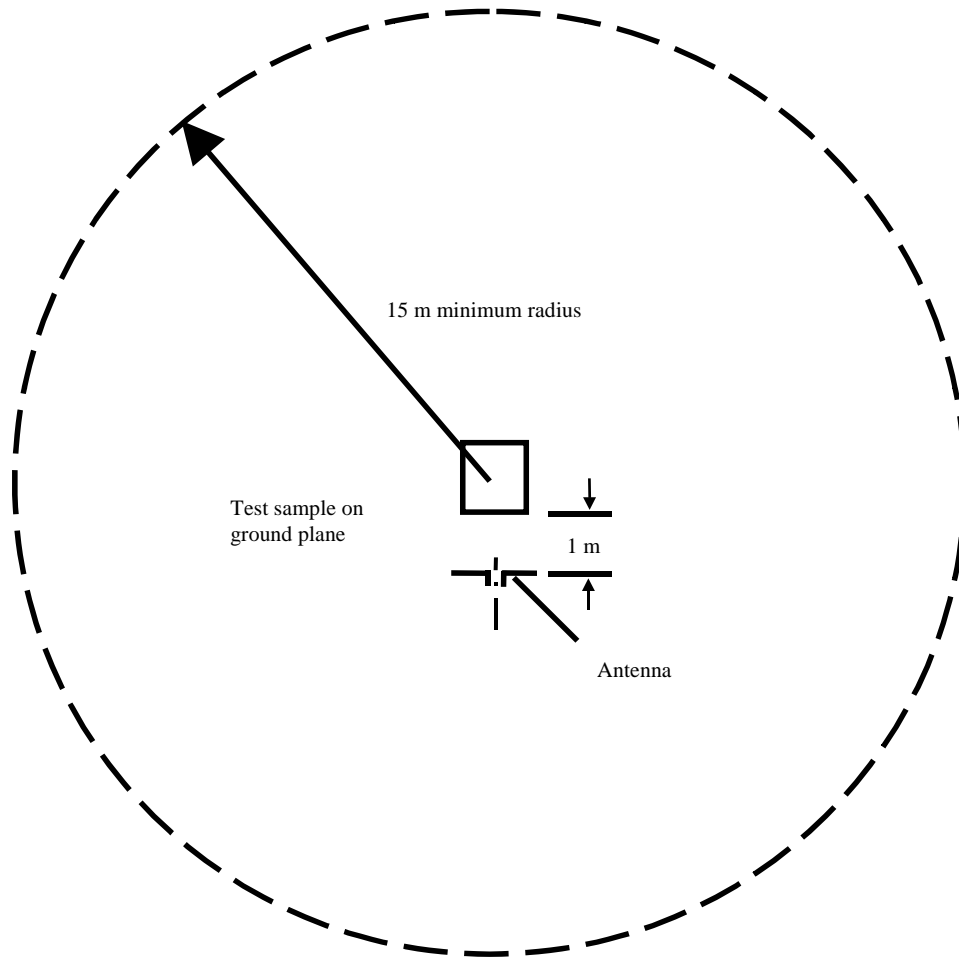

Figure 1

**Open Area Test Site: Electrical/electronic Sub-assembly Test Area Boundary
Level Clear Area Free from Electromagnetic Reflecting Surfaces**

ANNEX 6

(See 5.6.1)

**METHOD OF MEASUREMENT OF
RADIATED NARROWBAND ELECTROMAGNETIC EMISSIONS
FROM ELECTRICAL/ELECTRONIC SUB-ASSEMBLIES****1. GENERAL**

- 1.1. The test method described in this annex shall apply to ESAs, which may be subsequently fitted to vehicles, which comply, with Annex 3.

- 1.2 Test Method

This test is intended to measure the narrowband electromagnetic emissions such as might emanate from a microprocessor-based system.

If not otherwise stated in this annex the test shall be performed according to CISPR 25 (second edition 2002).

2. ESA STATE DURING TESTS

The ESA under test shall be in normal operation mode.

3. TEST ARRANGEMENTS

- 3.1. The test shall be performed according CISPR 25 (second edition 2002) clause 6.4. - ALSE method.

- 3.2. Alternative measuring location

As an alternative to an absorber lined shielded enclosure (ALSE) an open area test site (OATS) which complies with the requirements of CISPR 16-1 (second edition 2002) may be used (see Appendix 1 to Annex 5).

- 3.3. Ambient

To ensure that there is no extraneous noise or signal of a magnitude sufficient to affect materially the measurement, measurements shall be taken before or after the main test. In this measurement, the extraneous noise or signal shall be at least 6 dB below the limits of interference given in paragraph 5.6.2.1 of this standard, except for intentional narrowband ambient transmissions.

4. TEST REQUIREMENTS

- 4.1. The limits apply throughout the frequency range 30 to 1,000 MHz for measurements performed in semi anechoic chambers or outdoor test sites.
- 4.2. Measurements shall be performed with an average detector.

4.3. Measurements

The Test Agency shall perform the test at the intervals specified in the CISPR 25 (second edition 2002) standard throughout the frequency range 30 to 1,000 MHz.

Alternatively, if the manufacturer provides measurement data for the whole frequency band from a test laboratory accredited to the applicable parts of ISO 17025 (first edition 1999) and recognized by the Test Agency, the Test Agency may divide the frequency range in 13 frequency bands 30–50, 50-75, 75-100, 100-130, 130-165, 165-200, 200-250, 250-320, 320-400, 400-520, 520-660, 660-820, 820-1,000 MHz and perform tests at the 13 frequencies giving the highest emission levels within each band to confirm that the ESA meets the requirements of this annex. In the event that the limit is exceeded during the test, investigations shall be made to ensure that this is due to the ESA and not due to background radiation including broadband radiation from the ESA.

4.4. Readings

The maximum of the readings relative to the limit (horizontal/vertical polarisation) in each of the 13 frequency bands shall be taken as the characteristic reading at the frequency at which the measurements were made.

ANNEX 7

(See 5.7.1)

**METHOD(S) OF TESTING FOR IMMUNITY OF
ELECTRICAL/ELECTRONIC SUB-ASSEMBLIES TO
ELECTROMAGNETIC RADIATION****1. GENERAL**

- 1.1. The test methods described in this annex shall be applied to ESAs.
- 1.2. Test Methods
 - 1.2.1 ESAs may comply with the requirements of any combination of the following test methods at the manufacturer's discretion provided that this results in the full frequency range specified in paragraph 3.1. of this annex being covered:
 - (a) Absorber chamber test according ISO 11452-2, second edition 2004;
 - (b) TEM cell testing according ISO 11452-3, third edition 2001;
 - (c) Bulk current injection testing according ISO 11452-4, third edition 2005;
 - (d) Stripline testing according ISO 11452-5, second edition 2002;
 - (e) 800 mm stripline according to paragraph 5 of this annex.

(Frequency range and general test conditions shall be based on ISO 11452-1, third edition 2005).

2. STATE OF ESA DURING TESTS

- 2.1. The test conditions shall be according ISO 11452-1, third edition 2005.
- 2.2. The ESA under test shall be switched on and must be stimulated to be in normal operation condition. It shall be arranged as defined in this annex unless individual test methods dictate otherwise.
- 2.3. Any extraneous equipment required to operate the ESA under test shall not be in place during the calibration phase. No extraneous equipment shall be closer than 1 m from the reference point during calibration.
- 2.4. To ensure reproducible measurement results are obtained when tests and measurements are repeated, the test signal generating equipment and its layout shall be to the same specification as that used during each appropriate calibration phase.
- 2.5. If the ESA under test consists of more than one unit, the interconnecting cables should ideally be the wiring harnesses as intended for use in the vehicle. If these are not available, the length between the electronic control unit and the AN shall be as defined in the standard. All cables in the wiring harness should be terminated as realistically as possible and preferably with real loads and actuators.

3. GENERAL TEST REQUIREMENTS

3.1. Frequency range, dwell times

Measurements shall be made in the 20 to 2,000 MHz frequency range with frequency steps according to ISO 11452-1, third edition 2005.

The test signal modulation shall be:

(a) AM (amplitude modulation), with 1 kHz modulation and 80 per cent modulation depth in the 20 - 800 MHz frequency range;

(b) PM (pulse modulation), t_{on} 577 μ s, period 4,600 μ s in the 800 - 2,000 MHz frequency range,

if not otherwise agreed between Test Agency and ESA manufacturer.

Frequency step size and dwell time shall be chosen according to ISO 11452-1, third edition 2005.

3.2. The Test Agency shall perform the test at the intervals specified in ISO 11452-1, third edition 2005 throughout the frequency range 20 to 2,000 MHz.

Alternatively, if the manufacturer provides measurement to data for the whole frequency band from a test laboratory accredited to the applicable parts of ISO 17025, first edition 1999 and recognized by the Test Agency, the Test Agency may choose a reduced number of spot frequencies in the range, e.g. 27, 45, 65, 90, 120, 150, 190, 230, 280, 380, 450, 600, 750, 900, 1,300, and 1,800 MHz to confirm that the ESA meets the requirements of this annex.

3.3. If an ESA fails the tests defined in this annex, it must be verified as having failed under the relevant test conditions and not as a result of the generation of uncontrolled fields.

4. SPECIFIC TEST REQUIREMENTS

4.1. Absorber chamber test

4.1.1. Test method

This test method allows the testing of vehicle electrical/electronic systems by exposing an ESA to electromagnetic radiation generated by an antenna.

4.1.2. Test methodology

The "substitution method" shall be used to establish the test field conditions according ISO 11452-2, second edition 2004.

The test shall be performed with vertical polarization.

4.2. TEM cell testing (see Appendix 2 to this annex)

4.2.1. Test method

The TEM (transverse electromagnetic mode) cell generates homogeneous fields between the internal conductor (septum) and housing (ground plane).

4.2.2. Test methodology

The test shall be performed according ISO 11452-3, third edition 2001.

Depending on the ESA to be tested the Test Agency shall chose the method of maximum field coupling to the ESA or to the wiring harness inside the TEM-cell.

4.3. Bulk current injection testing

4.3.1. Test method

This is a method of carrying out immunity tests by inducing currents directly into a wiring harness using a current injection probe.

4.3.2. Test methodology

The test shall be performed according to ISO 11452-4, third edition 2005 on a test bench. As an alternative the ESA may be tested while installed in the vehicle according to ISO 11451-4 (first edition 1995) with the following characteristics:

- (a) the injection probe shall be positioned in 150 mm distance to the ESA to be tested;
- (b) the reference method shall be used to calculate injected currents from forward power;
- (c) the frequency range of the method is limited by the injection probe specification.

4.4. Stripline testing

4.4.1. Test method

This test method consists of subjecting the wiring harness connecting the components in an ESA to specified field strengths.

4.4.2. Test methodology

The test shall be performed according ISO 11452-5, second edition 2002.

4.5. 800 mm stripline testing

4.5.1. Test method

The stripline consists of two parallel metallic plates separated by 800 mm. Equipment under test is positioned centrally between the plates and subjected to an electromagnetic field (see Appendix 1 to this annex).

This method can test complete electronic systems including sensors and actuators as well as the controller and wiring loom. It is suitable for apparatus whose largest dimension is less than one –third of the plate separation.

4.5.2. Test methodology

4.5.2.1. Positioning of stripline

The stripline shall be housed in a screened room (to prevent external emissions) and positioned 2 m away from walls and any metallic enclosure to prevent electromagnetic reflections. RF absorber material may be used to damp these reflections. The stripline shall be placed on non-conducting supports at least 0.4 m above the floor.

4.5.2.2. Calibration of the stripline

A field-measuring probe shall be positioned within the central one-third of the longitudinal, vertical and transverse dimensions of the space between the parallel plates with the system under test absent.

The associated measuring equipment shall be sited outside the screen room. At each desired test frequency, a level of power shall be fed into the stripline to produce the required field strength at the antenna. This level of forward power, or another parameter directly related to the forward power required to define the field, shall be used for type approval tests unless changes occur in the facilities or equipment, which necessitate this procedure being repeated.

4.5.2.3. Installation of the ESA under test

The main control unit shall be positioned within the central one third of the longitudinal, vertical and transverse dimensions of the space between the parallel plates. It shall be supported on a stand made from non-conducting material.

4.5.2.4. Main wiring loom and sensor/actuator cables

The main wiring loom and any sensor/actuator cables shall rise vertically from the control unit to the top ground plate (this helps to maximize coupling with the electromagnetic field). Then they shall follow the underside of the plate to one of its free edges where they shall loop over and follow the top of the ground plate as far as the connections to the stripline feed. The cables shall then be routed to the associated equipment, which shall be sited in an area outside the influence of the electromagnetic field, e.g.: on the floor of the screened room 1 m longitudinally away from the stripline.

ANNEX 7 - APPENDIX 1

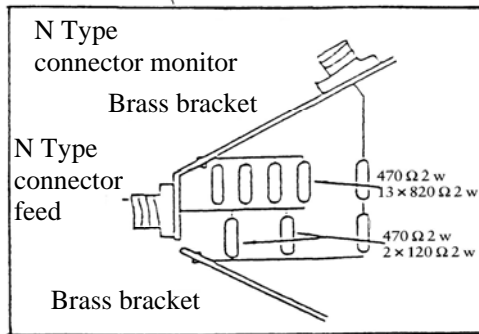
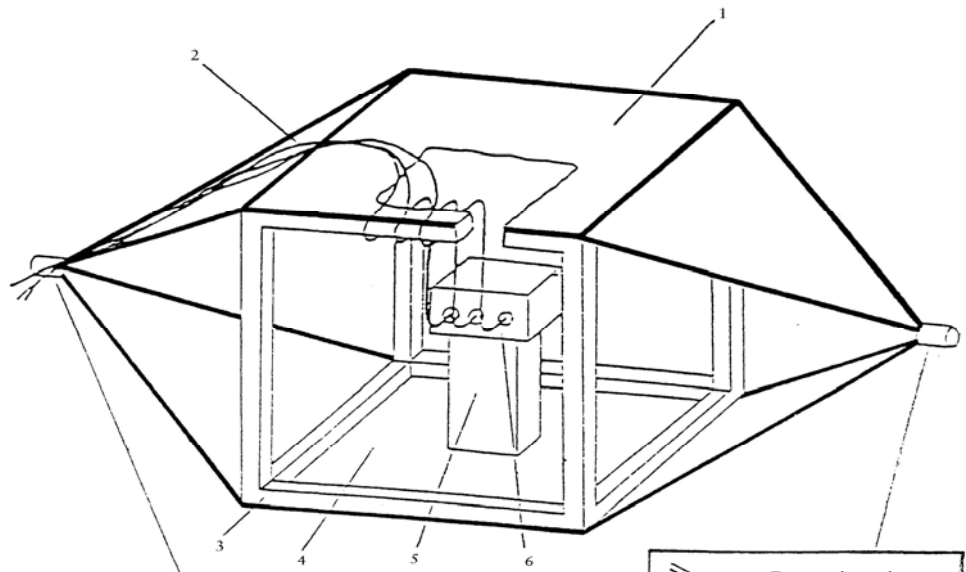

Details of stripline feed

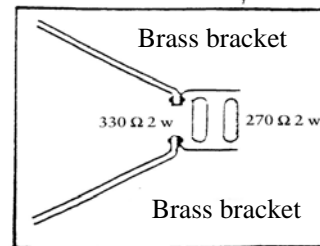

- 1 = Ground plate
- 2 = Main loom and sensor/actuator cables
- 3 = Wooden frame
- 4 = Driven plate
- 5 = Insulator
- 6 = Test object

Figure 1

800 mm Stripline Testing

ANNEX 7 - APPENDIX 1 (cont'd)

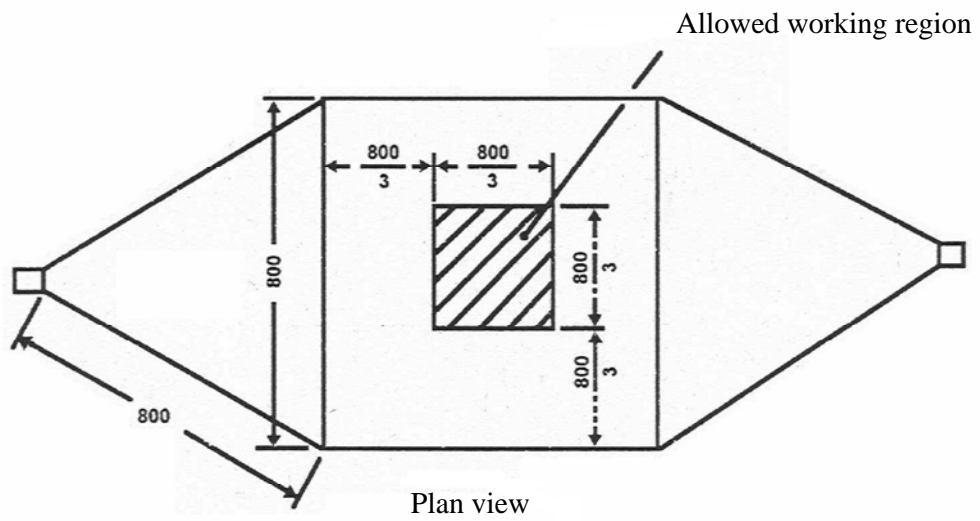
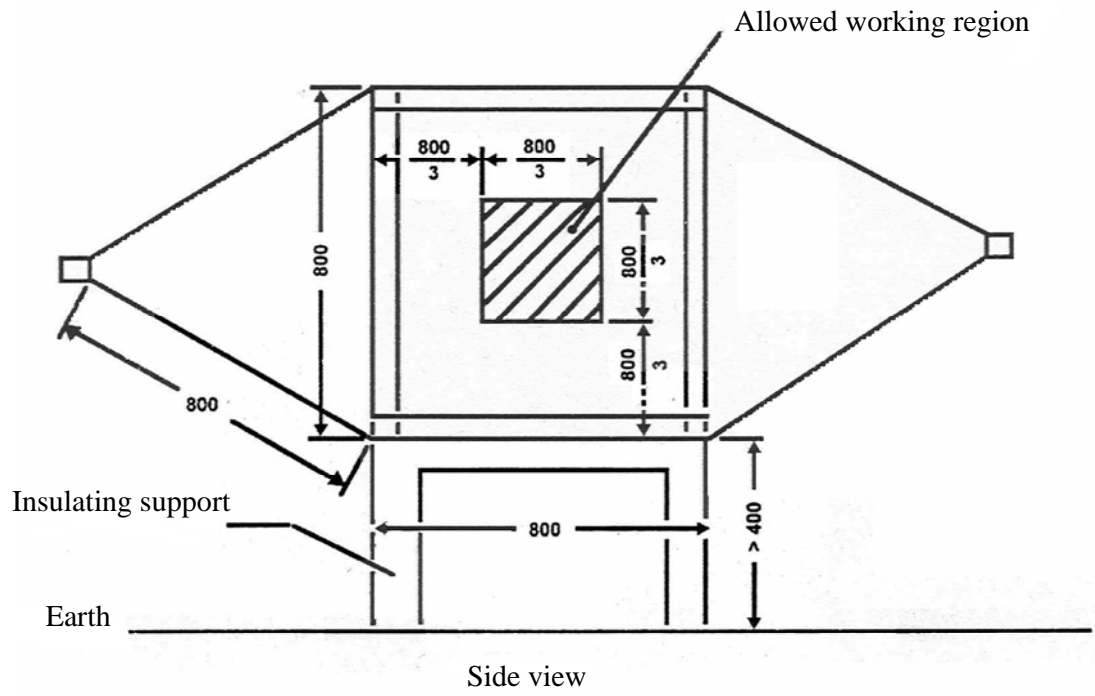

All dimensions in millimetres

Figure 2
800 mm Stripline Dimensions

ANNEX 7 - APPENDIX 2**TYPICAL TEM CELL DIMENSIONS**

The following table shows the dimensions for constructing a cell with specified upper frequency limits:

Upper frequency (MHz)	Cell form factor W : b	Cell form factor L/W	Plate separation b (cm)	Septum S (cm)
200	1.69	0.66	56	70
200	1.00	1	60	50

ANNEX 8

(See 5.8.1)

**METHOD(S) OF TESTING FOR IMMUNITY TO
AND EMISSION OF TRANSIENTS OF
ELECTRICAL/ELECTRONIC SUB-ASSEMBLIES****1. GENERAL**

This test method shall ensure the immunity of ESAs to conducted transients on the vehicle power supply and limit conducted transients from ESAs to the vehicle power supply.

**2. IMMUNITY AGAINST DISTURBANCES CONDUCTED ALONG
SUPPLY LINES**

Apply the test pulses 1, 2a, 2b, 3a 3b and 4 according to the International Standard ISO 7637-2: 2004 to the supply lines as well as to other connections of ESAs which may be operationally connected to supply lines.

**3. EMISSION OF CONDUCTED DISTURBANCES ALONG SUPPLY
LINES**

Measurement according to the International Standard ISO 7637-2: 2004 on supply lines as well as to other connections of ESAs which may be operationally connected to supply lines.

ANNEX 9A

(See 8.2)

**GUIDELINES FOR DECIDING APPLICABILITY,
WORST CASE CRITERIA (WCC) AND CRITERIA FOR
EXTENSION OF APPROVAL (CEA) FOR RADIATED IMMUNITY TEST****Applicability:**

1. Vehicle fitted with any of the Electronic Sub-Assembly (ESA) as per list given below shall be subjected to immunity test:

Sr. No.	ESA
1.	Electronic Engine Control Unit (ECU) for <ul style="list-style-type: none"> • Fuel injection • Ignition timing control • Combined fuel injection and ignition timing control • Engine valve control • EGR • Idle speed control • Exhaust emission / after-treatment control • Air-fuel ratio control • Electronic carburetor
2.	Drive by Wire System (Electronic Accelerator Pedal and/or Electronic Brake)
3.	Cruise Control System
4.	Anti-skid Braking System (ABS)
5.	Electronic 4-wheel Drive
6.	Electronic Gear Shift Control System (Automatic Transmission or CVT)
7.	Electronic Steering Control (Electronic Power Steering)
8.	Motor Control Unit in case of BOVs
9.	Electronic Speed Limiter
10.	Air Bag and Safety Restraint System
11.	Electronic Seat Adjustment Control System
12.	Electronic Rear View, Side View Mirror Adjustment Control System
13.	Electronic Lamp Control Device
14.	Electronic Headlamp Leveling / Adjustment System
15.	Gas-discharge Headlamp with Electronic Ballast
16.	Electronic Rotating Identification Lamp and/or Siren Combination

17.	Stop Lamp, Rear Position Lamp, End Outline Marker Lamp using Electronic Components such as LED etc.
18.	Electronic Flasher with Direction Indicators
19.	Electronic Horn
20.	Electronic Anti-theft Device for Unauthorised Use including RF Immobiliser and Vehicle Alarm System
21.	Automatic Door Lock System including Infrared Door Lock System
22.	Electronic Suspension Control
23.	Electronic Instrument Cluster including on-board indicators related to functions as specified in Cl. 2.12
24.	Navigation System
25.	Wiper Control System
26.	Tire Pressure Monitoring System
27.	Digital Tachograph
28.	Telematic System

The above list is not exhaustive and it is for guidance only. Due to continuous technological advancements, it is not practicable to list all the ESAs that will require immunity test. In such case, guidelines for immunity related vehicle functions as per Cl. 2.12 shall be considered.

- Any change in parameters mentioned below will require separate immunity test as per below:

Sr. No.	Parameter	Immunity Test Needed	Remarks
1.	Change in engine location	Yes	Change in position and general mounting arrangement of engine consequent to situations like front engine to rear engine etc.
2.	Change in body style and or material affecting overall shielding of vehicle electronics	Yes	e.g. roof top body, drive away chassis, passenger vehicle to goods vehicle, metallic body to non-metallic body and vice versa etc.
3.	Change in make, identification mark/part number of ESA as a result of change in design of hardware or vendor of ESA or addition of new ESA altogether.	Yes	These changes affect immunity performance of ESA and hence that of the vehicle.

Changes other than those listed above are considered to be having no adverse effect on Immunity requirements of vehicle.

Worst Case Criteria (WCC):

Normally base vehicle model shall be subjected to immunity test. Where vehicle model is with one or more variants then the variant with fully loaded version (variant fitted with maximum electronic systems including optional ones) and one with fully open body (e.g. drive away chassis as the case may be) shall be subjected to the immunity test. Bi-fuel vehicle model (e.g. petrol/CNG, petrol/LPG) with petrol mode as limp-home mode shall be tested only in gaseous mode for immunity if it involves ESAs as above. Bi-fuel vehicle model with no limp-home mode shall be tested separately in each fuel mode for immunity if it involves ESAs as above. However, if petrol mode of such vehicle model is tested and type approved for immunity requirements as per this standard earlier, then it shall not be retested in petrol mode again.

Criteria for Extension of Approval (CEA):

In the whole vehicle testing, ESAs that are fitted to the vehicle gain approval as a separate technical unit specific to that vehicle type. For any change in ESA or addition of new ESA in the vehicle, immunity test can be performed either on ESA as a component or as fitted to the vehicle. ESAs can be tested and approved for immunity requirements as a component and extension of type approval can be granted to vehicle based on component approval when such ESAs are incorporated in the vehicle. ESAs approved as component can be fitted in any vehicle type.

ANNEX 9B

(See 8.2)

**GUIDELINES FOR DECIDING APPLICABILITY,
WORST CASE CRITERIA (WCC) AND CRITERIA FOR
EXTENSION OF APPROVAL (CEA) FOR RADIATED EMISSION TEST**

1. This annex gives factors to be considered for the extension of type approval certificate of one model to changes in technical specifications or its variant (s).
2. In general, when changes in technical specifications of vehicle do not affect the performance adversely, and is still within the stipulated limits, the type approval certificates can be extended. The changes in parameters that affect the performance are listed in the table below as a guideline.
3. In the case of following changes, with respect to the vehicle tested, in the details submitted as per Annex 1A, tests are necessary for establishing compliance as follows:-

Sr. No.	PARAMETER	TO BE TESTED / NOT TESTED
1	Change in Engine Power	No test, required, if change in power is within 10 % consequent to changes in the design of engine
2	Compression ratio (SI engines)	No test required, if change in compression ratio is within 10 %.
3	Changes in body and cowling	For changes in overall external body shape like closed body to open body (e.g. drive away chassis as the case may be) test needed
4	Changes in size and shape of engine compartment.	Test needed.
5	Location of HT Coil and consequent change in location of HT cable & high tension harness.	Test needed.
6	Change in body material such as metal to non - metal & vice - versa.	Test needed.
7	Change in the position and general mounting arrangement of engine consequent to situations like front engine to rear engine vice - versa etc.	Test needed.
8	Change in radio interference control equipment such as resistive spark plug, resistive suppressor cap, resistive HT cable and shielded cap as declared in sr. no. 56 of Annex 1A and/or their makes	Test needed.

9	Addition of any electronic control unit as defined in Cl. 3.1.3	Test needed.
10	Changes in electronic oscillator frequency of electronic control unit(s) as defined in 5.10.1	Test needed.
11	Addition of AC (air conditioning) variant	Test needed.
12	Significant difference in the clear opening to engine compartment - around wheel or - due to metal radiator construction change.	Test needed.
13	Changes in body material affecting RF shielding	Test needed
14	Bi-fuel vehicle model (e.g. petrol/CNG, petrol/LPG) with / without petrol mode as limp-home mode	Test needed in gaseous mode only

4. Above changes are listed for guidance only. It is not practicable to list all the changes those affect EMI.

ANNEX 10
(See Introduction)

COMMITTEE COMPOSITION *
Automotive Industry Standards Committee

Chairman	
Shri Shrikant R. Marathe	Director The Automotive Research Association of India, Pune
Members	Representing
Representative from	Ministry of Shipping, Road Transport & Highways (Dept. of Road Transport & Highways), New Delhi
Representative from	Ministry of Heavy Industries & Public Enterprises (Department of Heavy Industry), New Delhi
Shri S. M. Ahuja	Office of the Development Commissioner, MSME, Ministry of Micro, Small & Medium Enterprises, New Delhi
Shri Rakesh Kumar	Bureau of Indian Standards, New Delhi
Director Shri D. P. Saste (Alternate)	Central Institute of Road Transport, Pune
Dr. M. O. Garg	Indian Institute of Petroleum, Dehra Dun
Dr. C. L. Dhamejani	Vehicles Research & Development Establishment, Ahmednagar
Representatives from	Society of Indian Automobile Manufacturers
Shri T.C. Gopalan	Tractor Manufacturers Association, New Delhi
Shri K.N.D. Nambudiripad	Automotive Components Manufacturers Association of India, New Delhi
Shri Arvind Gupta	Automotive Components Manufacturers Association of India, New Delhi

Member Secretary
Mrs. Rashmi Urdhwareshe
Deputy Director
The Automotive Research Association of India, Pune

* At the time of approval of this Automotive Industry Standard (AIS)